



T2.2-8: Availability of Equipment and Other Resources

The Tenderer to submit a list of all Equipment and other resources that will be used to execute the *works* as described in the Works Information.

Equipment Type and Availability – Description	Hourly Rate	Number of Equipment	Details of Ownership

T2.2-9: Record of Addenda to Tender Documents

This schedule as submitted confirms that the following communications received from the *Employer* before the submission of this tender offer, amending the tender documents, have been taken into account in this specific tender offer:

	Date	Title or Details
1		
2		
3		
4		
5		
6		
7		
8		
9		
10		
11		
12		
13		
14		
15		

T2.2-11: SPECIFICATION E4.B

MINIMUM COMMUNAL HEALTH REQUIREMENTS IN AREAS OUTSIDE THE JURISDICTION OF A LOCAL AUTHORITY: TEMPORARY FACILITIES FOR CONTRACTOR'S PERSONNEL

1. CAMPS

- 1.1 Prior to the erection of any camp, the Contractor shall submit to the Technical Officer, for his approval, details of his proposals as to the site, water supply, sanitation, and size and type of buildings. Where the site is on private land, the Contractor shall submit the written approval for the use of the site of the relevant statutory authority and of the owner and occupier of the land (as applicable).
- 1.2 Camps must not be erected on land infested with field rodents.
- 1.3 Adequate drainage shall be provided to carry off storm and waste water.
- 1.4 Buildings shall be built to a neat and orderly pattern.
- 1.5 All buildings shall have smooth, hard, impervious floors, graded to provide effective drainage and to permit washing.
- 1.6 Camps shall be maintained by the Contractor at his own expense in a clean and tidy condition. The Contractor shall take such steps as the Technical Officer and landowner/occupier may demand to prevent the creation of a nuisance.
- 1.7 When so instructed by the Technical Officer, the Contractor shall, at his own expense, erect suitable screens between the camp and any public road, thoroughfare or railway line.
- 1.8 After removal of a camp, the Contractor shall, at his own expense, restore the site to its original condition to the satisfaction of the Technical Officer and of the landowner and occupier where the site is on private land.

2. HOUSING

- 2.1 Every living room shall have cross ventilation, both constant and occasional. Where only one window is provided, it shall not be in the same wall as the door.
- 2.2 Dimensions of living rooms shall be sufficient to allow 3.5 square metres of floor area and 11 cubic metres of air space for each person over the age of 10 years. The floor area of any living room shall not be less than 7,8 square metres.

- 2.3 Flat-roofed quarters shall have a minimum roof height of 3 metres above floor level. For quarters with pitched roofs, the wall height shall be not less than 2,6 metres above the floor with a minimum height above floor of 3 metres at the top of the pitch.
- 2.4 Doors shall not be less than 2m x 0,75m and must be halved.
- 2.5 Windows of each living room shall have an area not less than one twelfth of the floor area and shall be capable of opening to at least half their full area.
- 2.6 In areas where malaria is prevalent, doors and windows must be fitted with gauze screens.
- 2.7 Cooking shelters shall comprise roofed structures, three sides of which shall be enclosed by a weatherproof material, approved by the Technical Officer to a height of at least **1m** above ground level.
 - 2.7.1 Sleeping quarters shall not accommodate more than 8 persons per room.
 - 2.7.2 Pegboards shall be carried on metal or concrete supports and shall be separated by partitions not less than 0,4 metres high extending to within 150mm of the end of the bunk. Pegboards shall be removable for cleaning.

3. **WATER SUPPLY AND ABLUTION FACILITIES**

- 3.1 The Contractor shall ensure that an adequate and conveniently situated supply of potable water is provided.
- 3.2 Separate buildings for ablution facilities shall be provided. Where approval has been obtained for the housing of both males and females, separate facilities for each gender shall be provided. The proportion shall be 1 cubicle for 20 persons.
- 3.3 Waste water shall be hygienically disposed of.

4. **SANITATION**

- 4.1 Separate buildings for latrine facilities shall be provided. Where housing are provided for both males and females, separate facilities for each gender shall be provided. The proportions shall be at least one squatting seat for every 15 persons or less in the case of pit latrines, or one for every 10 persons or less in case of pail latrines.

Latrines shall be fly proof and sited at least 10 metres from any other building, and shall not face on any public road, thoroughfare, railway line or residential property. Pits shall not be less than 2,5 metres deep and sited not less than 120 metres from nearest underground water source.

- 4.2 Latrines shall be so constructed, situated and maintained, and night soil so disposed of as to prevent access by animals, breeding of flies, pollution of streams and domestic water supplies, and other nuisances. Where a night soil removal service is operated by a competent authority, use of such service shall be obligatory, and the use of pit latrines and atria pits will not be permitted.
- 4.3 At least one refuse bin of adequate size with close fitting lid shall be provided for each building. Refuse bins shall be emptied and cleaned out daily.
- 4.4 Labour shall be employed on camp sanitation duties on the following basis:-
 - 4.4.1 Where the number of persons living at the camp is 20 or less - one unit.
 - 4.4.2 For additional numbers over 20 living at the camp - one unit per 100 or part thereof.
- 4.5 Unless refuse is removed by a competent authority, it shall be disposed of in pits and covered over daily with a layer of earth or ash of sufficient thickness to prevent depredations by rodents and the breeding of flies.
- 4.6 Adequate measures shall be taken against all vermin and insects responsible for the spread of disease. Any instructions of a competent health authority shall be carried out promptly and implicitly.
- 4.7 Buildings and bedboards shall be treated whenever necessary with an approved insecticide.
- 4.8 The Contractor shall permit and facilitate inspection of the camp and structures on the site by the staff of Transnet or any other competent authority, and shall comply with any reasonable request by such staff or any other competent authority to eliminate any unsanitary condition.
- 4.9 Any outbreak of infectious disease shall immediately be reported telephonically and confirmed in writing to the Technical Officer.
- 4.10 The keeping of animals of any sort is not permitted.
- 4.11 The Contractor shall have on hand at the camp the necessary tools, disinfectants and cleaning materials to maintain and clean the sanitary facilities.

5. **RATIONS**

Rations, where supplied by the Contractor, shall be stored in a suitable and rodent proof building with sufficient shelving.

P02b-06 (JLH)



T2.2-12: Health and Safety Requirements

Submit the following documents as a minimum with your tender:

1. The Tenderers must provide their own project specific health and safety Plan.
2. Health and safety cost breakdown (Bill of Quantities)
3. Safety, Policy signed by the Chief Executive Officer, must include or cover the following five elements –
 - Commitment to Safety, prevention of pollution,
 - Continual improvement,
 - Compliance to legal requirements, appropriate to the nature of contractor’s activities,
 - Hold management accountable for development of the safety systems
 - Include objectives and targets.
4. Table or outline the Roles & Responsibilities, such as S16.2 CEO, CR8.1 Construction manager, CR8.2 Assistant Construction manager, CR8.5 Safety officer, CR8.7 Construction Supervisor, CR8.8 Construction assistant supervisor, CR9.1 Risk Assessor, 17.1 SHE Reps, etc. as per the Occupational health and safety Act 85 of 1993
5. List of job categories for project and competencies required per category and develop a training Matrix for all employees who will be working on the project. This matrix must include Management and highlight training planned dates.
6. Overview of the project specific Baseline Risk Assessment (RA), indicating major activities of the project
7. **Three years** synopsis of SHE incidents, description, type and action taken to prevent re-occurrence.
8. Complete and return with tender documentation the Contractor Safety Questionnaire included as an Annexure B.

Attached submissions to this schedule:

.....
.....
.....
.....
.....
.....
.....
.....
.....
.....



T2.2-12a: Health and Safety Questionnaire

Health, Safety Questionnaire

1. SAFE WORK PERFORMANCE													
1A. Injury Experience / Historical Performance - Alberta													
Use the previous three years injury and illness records to complete the following:													
Year													
Number of medical treatment cases													
Number of restricted work day cases													
Number of lost time injury cases													
Number of fatal injuries													
Total recordable frequency													
Lost time injury frequency													
Number of worker manhours													
<table border="1" style="width: 100%; border-collapse: collapse;"> <tr> <td style="width: 30%;">1 - Medical Treatment Case</td> <td>Any occupational injury or illness requiring treatment provided by a physician or treatment provided under the direction of a physician</td> </tr> <tr> <td>2 - Restricted Work Day Case</td> <td>Any occupational injury or illness that prevents a worker from performing any of his/her craft jurisdiction duties</td> </tr> <tr> <td>3 - Lost Time injury Cases</td> <td>Any occupational injury that prevents the worker from performing any work for at least one day</td> </tr> <tr> <td>4 - Total Recordable Frequency</td> <td>Total number of Medical Treatment, Restricted Work and Lost Time Injury cases multiplied by 200,000 then divided by total manhours</td> </tr> <tr> <td>5- Lost Time Injury Frequency</td> <td>Total number of Lost Time Injury cases multiplied by 200,000 then divide by total manhours</td> </tr> </table>				1 - Medical Treatment Case	Any occupational injury or illness requiring treatment provided by a physician or treatment provided under the direction of a physician	2 - Restricted Work Day Case	Any occupational injury or illness that prevents a worker from performing any of his/her craft jurisdiction duties	3 - Lost Time injury Cases	Any occupational injury that prevents the worker from performing any work for at least one day	4 - Total Recordable Frequency	Total number of Medical Treatment, Restricted Work and Lost Time Injury cases multiplied by 200,000 then divided by total manhours	5- Lost Time Injury Frequency	Total number of Lost Time Injury cases multiplied by 200,000 then divide by total manhours
1 - Medical Treatment Case	Any occupational injury or illness requiring treatment provided by a physician or treatment provided under the direction of a physician												
2 - Restricted Work Day Case	Any occupational injury or illness that prevents a worker from performing any of his/her craft jurisdiction duties												
3 - Lost Time injury Cases	Any occupational injury that prevents the worker from performing any work for at least one day												
4 - Total Recordable Frequency	Total number of Medical Treatment, Restricted Work and Lost Time Injury cases multiplied by 200,000 then divided by total manhours												
5- Lost Time Injury Frequency	Total number of Lost Time Injury cases multiplied by 200,000 then divide by total manhours												
1B. Workers' Compensation Experience													
Use the previous three years injury and illness records to complete the following (if applicable):													
Industry Code:		Industry Classification:											
Year													
Industry Rate													
Contractor Rate													
% Discount or Surcharge													
Is your Workers' Compensation account in good standing? (Please provide letter of confirmation)		<input type="checkbox"/> Yes <input type="checkbox"/> No											
2. CITATIONS													
2A.	Has your company been cited, charged or prosecuted under Health, Safety and/or Environmental Legislation in the last 5 years? <input type="checkbox"/> Yes <input type="checkbox"/> No If yes, provide details:												
2B.	Has your company been cited, charged or prosecuted under the above Legislation in another Country, Region or State? <input type="checkbox"/> Yes <input type="checkbox"/> No If yes, provide details:												



3. CERTIFICATE OF RECOGNITION

Does your company have a Certificate of Recognition?

Yes No If Yes, what is the Certificate No. _____ Issue Date _____

4. SAFETY PROGRAM

Do you have a written safety program manual? Yes No

If Yes, provide a copy for review

Do you have a pocket safety booklet for field distribution? Yes No

If Yes, provide a copy for review

Does your safety program contain the following elements:

	YES	NO		YES	NO
CORPORATE SAFETY POLICY	<input type="checkbox"/>	<input type="checkbox"/>	EQUIPMENT MAINTENANCE	<input type="checkbox"/>	<input type="checkbox"/>
INCIDENT NOTIFICATION POLICY	<input type="checkbox"/>	<input type="checkbox"/>	EMERGENCY RESPONSE	<input type="checkbox"/>	<input type="checkbox"/>
RECORDKEEPING & STATISTICS	<input type="checkbox"/>	<input type="checkbox"/>	HAZARD ASSESSMENT	<input type="checkbox"/>	<input type="checkbox"/>
REFERENCE TO LEGISLATION	<input type="checkbox"/>	<input type="checkbox"/>	SAFE WORK PRACTICES	<input type="checkbox"/>	<input type="checkbox"/>
GENERAL RULES & REGULATIONS	<input type="checkbox"/>	<input type="checkbox"/>	SAFE WORK PROCEDURES	<input type="checkbox"/>	<input type="checkbox"/>
PROGRESSIVE DISCIPLINE POLICY	<input type="checkbox"/>	<input type="checkbox"/>	WORKPLACE INSPECTIONS	<input type="checkbox"/>	<input type="checkbox"/>
RESPONSIBILITIES	<input type="checkbox"/>	<input type="checkbox"/>	INVESTIGATION PROCESS	<input type="checkbox"/>	<input type="checkbox"/>
PPE STANDARDS	<input type="checkbox"/>	<input type="checkbox"/>	TRAINING POLICY & PROGRAM	<input type="checkbox"/>	<input type="checkbox"/>
ENVIRONMENTAL STANDARDS	<input type="checkbox"/>	<input type="checkbox"/>	COMMUNICATION PROCESSES	<input type="checkbox"/>	<input type="checkbox"/>
MODIFIED WORK PROGRAM	<input type="checkbox"/>	<input type="checkbox"/>			

5. TRAINING PROGRAM

5A. Do you have an orientation program for new hire employees? Yes No

If Yes, include a course outline. Does it include any of the following:

	YES	NO		YES	NO
GENERAL RULES & REGULATIONS	<input type="checkbox"/>	<input type="checkbox"/>	CONFINED SPACE ENTRY	<input type="checkbox"/>	<input type="checkbox"/>
EMERGENCY REPORTING	<input type="checkbox"/>	<input type="checkbox"/>	TRENCHING & EXCAVATION	<input type="checkbox"/>	<input type="checkbox"/>
INJURY REPORTING	<input type="checkbox"/>	<input type="checkbox"/>	SIGNS & BARRICADES	<input type="checkbox"/>	<input type="checkbox"/>
LEGISLATION	<input type="checkbox"/>	<input type="checkbox"/>	DANGEROUS HOLES & OPENINGS	<input type="checkbox"/>	<input type="checkbox"/>
RIGHT TO REFUSE WORK	<input type="checkbox"/>	<input type="checkbox"/>	RIGGING & CRANES	<input type="checkbox"/>	<input type="checkbox"/>
PERSONAL PROTECTIVE EQUIPMENT	<input type="checkbox"/>	<input type="checkbox"/>	MOBILE VEHICLES	<input type="checkbox"/>	<input type="checkbox"/>
EMERGENCY PROCEDURES	<input type="checkbox"/>	<input type="checkbox"/>	PREVENTATIVE MAINTENANCE	<input type="checkbox"/>	<input type="checkbox"/>
PROJECT SAFETY COMMITTEE	<input type="checkbox"/>	<input type="checkbox"/>	HAND & POWER TOOLS	<input type="checkbox"/>	<input type="checkbox"/>
HOUSEKEEPING	<input type="checkbox"/>	<input type="checkbox"/>	FIRE PREVENTION & PROTECTION	<input type="checkbox"/>	<input type="checkbox"/>
LADDERS & SCAFFOLDS	<input type="checkbox"/>	<input type="checkbox"/>	ELECTRICAL SAFETY	<input type="checkbox"/>	<input type="checkbox"/>
FALL ARREST STANDARDS	<input type="checkbox"/>	<input type="checkbox"/>	COMPRESSED GAS CYLINDERS	<input type="checkbox"/>	<input type="checkbox"/>
AERIAL WORK PLATFORMS	<input type="checkbox"/>	<input type="checkbox"/>	WEATHER EXTREMES	<input type="checkbox"/>	<input type="checkbox"/>



5B. Do you have a program for training newly hired or promoted supervisors? Yes No

(If Yes, submit an outline for evaluation. Does it include instruction on the following:

	Yes	No		Yes	No
EMPLOYER RESPONSIBILITIES	<input type="checkbox"/>	<input type="checkbox"/>	SAFETY COMMUNICATION	<input type="checkbox"/>	<input type="checkbox"/>
EMPLOYEE RESPONSIBILITIES	<input type="checkbox"/>	<input type="checkbox"/>	FIRST AID/MEDICAL PROCEDURES	<input type="checkbox"/>	<input type="checkbox"/>
DUE DILIGENCE	<input type="checkbox"/>	<input type="checkbox"/>	NEW WORKER TRAINING	<input type="checkbox"/>	<input type="checkbox"/>
SAFETY LEADERSHIP	<input type="checkbox"/>	<input type="checkbox"/>	ENVIRONMENTAL REQUIREMENTS	<input type="checkbox"/>	<input type="checkbox"/>
WORK REFUSALS	<input type="checkbox"/>	<input type="checkbox"/>	HAZARD ASSESSMENT	<input type="checkbox"/>	<input type="checkbox"/>
INSPECTION PROCESSES	<input type="checkbox"/>	<input type="checkbox"/>	PRE-JOB SAFETY INSTRUCTION	<input type="checkbox"/>	<input type="checkbox"/>
EMERGENCY PROCEDURES	<input type="checkbox"/>	<input type="checkbox"/>	DRUG & ALCOHOL POLICY	<input type="checkbox"/>	<input type="checkbox"/>
INCIDENT INVESTIGATION	<input type="checkbox"/>	<input type="checkbox"/>	PROGRESSIVE DISCIPLINARY POLICY	<input type="checkbox"/>	<input type="checkbox"/>
SAFE WORK PROCEDURES	<input type="checkbox"/>	<input type="checkbox"/>	SAFE WORK PRACTICES	<input type="checkbox"/>	<input type="checkbox"/>
SAFETY MEETINGS	<input type="checkbox"/>	<input type="checkbox"/>	NOTIFICATION REQUIREMENTS	<input type="checkbox"/>	<input type="checkbox"/>

6. SAFETY ACTIVITIES

Do you conduct safety inspections? Yes No Weekly Monthly Quarterly

Describe your safety inspection process (include participation, documentation requirements, follow-up, report distribution).

Who follows up on inspection action items? _____

Do you hold site safety meetings for field employees? If Yes, how often?

Yes No Daily Weekly Biweekly

Do you hold site meetings where safety is addressed with management and field supervisors?

Yes No Weekly Biweekly Monthly

Is pre-job safety instruction provided before to each new task? Yes No

Is the process documented? Yes No

Who leads the discussion? _____

Do you have a hazard assessment process? Yes No

- Are hazard assessments documented? If yes, how are hazard assessments communicated and implemented on each project? Who is responsible for leading the hazard assessment process?

Does your company have policies and procedures for environmental protection, spill clean-up, reporting, waste disposal, and recycling as part of the Health & Safety Program?

Yes No

How does your company measure its H&S success?

- Attach separate sheet to explain

7. SAFETY STEWARDSHIP



7A Are incident reports and report summaries sent to the following and how often?					
	Yes	No	Monthly	Quarterly	Annually
Project/Site Manager	<input type="checkbox"/>	<input type="checkbox"/>	<input type="checkbox"/>	<input type="checkbox"/>	<input type="checkbox"/>
Managing Director	<input type="checkbox"/>	<input type="checkbox"/>	<input type="checkbox"/>	<input type="checkbox"/>	<input type="checkbox"/>
Safety Director/Manager	<input type="checkbox"/>	<input type="checkbox"/>	<input type="checkbox"/>	<input type="checkbox"/>	<input type="checkbox"/>
/Chief Executive Officer	<input type="checkbox"/>	<input type="checkbox"/>	<input type="checkbox"/>	<input type="checkbox"/>	<input type="checkbox"/>
7B How are incident records and summaries kept? How often are they reported internally?					
	Yes	No	Monthly	Quarterly	Annually
Incidents totaled for the entire company	<input type="checkbox"/>	<input type="checkbox"/>	<input type="checkbox"/>	<input type="checkbox"/>	<input type="checkbox"/>
Incidents totaled by project	<input type="checkbox"/>	<input type="checkbox"/>	<input type="checkbox"/>	<input type="checkbox"/>	<input type="checkbox"/>
• Subtotaled by superintendent	<input type="checkbox"/>	<input type="checkbox"/>	<input type="checkbox"/>	<input type="checkbox"/>	<input type="checkbox"/>
• Subtotaled by foreman	<input type="checkbox"/>	<input type="checkbox"/>	<input type="checkbox"/>	<input type="checkbox"/>	<input type="checkbox"/>
7C How are the costs of individual incidents kept? How often are they reported internally?					
	Yes	No	Monthly	Quarterly	Annually
Costs totaled for the entire company	<input type="checkbox"/>	<input type="checkbox"/>	<input type="checkbox"/>	<input type="checkbox"/>	<input type="checkbox"/>
Costs totaled by project	<input type="checkbox"/>	<input type="checkbox"/>	<input type="checkbox"/>	<input type="checkbox"/>	<input type="checkbox"/>
• Subtotaled by superintendent	<input type="checkbox"/>	<input type="checkbox"/>	<input type="checkbox"/>	<input type="checkbox"/>	<input type="checkbox"/>
• Subtotaled by foreman/general foreman	<input type="checkbox"/>	<input type="checkbox"/>	<input type="checkbox"/>	<input type="checkbox"/>	<input type="checkbox"/>
7D Does your company track non-injury incidents?					
	Yes	No	Monthly	Quarterly	Annually
Near Miss	<input type="checkbox"/>	<input type="checkbox"/>	<input type="checkbox"/>	<input type="checkbox"/>	<input type="checkbox"/>
Property Damage	<input type="checkbox"/>	<input type="checkbox"/>	<input type="checkbox"/>	<input type="checkbox"/>	<input type="checkbox"/>
Fire	<input type="checkbox"/>	<input type="checkbox"/>	<input type="checkbox"/>	<input type="checkbox"/>	<input type="checkbox"/>
Security	<input type="checkbox"/>	<input type="checkbox"/>	<input type="checkbox"/>	<input type="checkbox"/>	<input type="checkbox"/>
Environmental	<input type="checkbox"/>	<input type="checkbox"/>	<input type="checkbox"/>	<input type="checkbox"/>	<input type="checkbox"/>
8 PERSONNEL					
List key health and safety officers planned for this project. Attach resume.					
Name	Position/Title		Designation		
Supply name, address and phone number of your company's corporate health and safety representative. Does this individual have responsibilities other than health, safety and environment?					
Name	Address		Telephone Number		
Other responsibilities:					
9 REFERENCES					
List the last three company's your form has worked for that could verify the quality and management commitment to your occupational Health & Safety program					
Name and Company	Address		Phone Number		

T2.2-12c Health and Safety Cost Breakdown

Tenderer (Company)	Responsible Person	Designation	Date
Project/Tender Title	Project/Tender No.	Project Location / Description	

#	Cost element	Unit Cost (R)	# of Units	Total Cost (R)
1.	Human Resources			
2.	Systems Documentation			
3.	Meetings & Administration			
4.	H&S Training			
5.	PPE & Safety Equipment			
6.	Signage & Barricading			
7.	Workplace Facilities			
8.	Emergency & Rescue Measures			
9.	Hygiene Surveys & Monitoring			
10.	Medical Surveillance			
11.	Safe Transport of Workers			
12.	HazMat Management (e.g. asbestos /silica)			
13.	Substance Abuse Testing (3 kits @R500 pm)			
14.	H&S Reward & Recognition			

Total Health and Safety Estimate (R)	
Total Estimate Value (R)	
H&S Cost as % of Tender value	



T2.2-12d Letter/s of Good Standing with the Workmen's Compensation Fund

Attached to this schedule is the Letter/s of Good Standing.

- 1.
- 2.
- 3.
- 4.

Name of Company/Members of Joint Venture:

.....
.....
.....
.....
.....
.....
.....
.....
.....
.....
.....



T2.2-12e Section 37 Mandatory Agreement

MANDATORY AGREEMENT

OCCUPATIONAL HEALTH AND SAFETY ACT 85 of 1993 (AS AMENDED)

AGREEMENT WITH MANDATORY

In terms of Section 37(1) & (2)

WRITTEN AGREEMENT ENTERED INTO AND BETWEEN

Transnet SOC Ltd
(Hereinafter referred to as the Employer)

AND

(Hereinafter referred to as Mandatory (Principal Contractor))

Compensation Fund Number :

Project Name :

TABLE OF CONTENTS

- 1. DEFINITIONS**
- 2. INTERPRETATION**
- 3. REPORTING**
- 4. WARRANTY OF COMPLIANCE**
- 5. APPOINTMENTS AND TRAINING**
- 6. SUPERVISION, DISCIPLINE AND REPORTING**
- 7. ACCESS TO THE OHS ACT**
- 8. COOPERATION**
- 9. WORK PROCEDURES**
- 10. HEALTH AND SAFETY MEETINGS**
- 11. COMPENSATION REGISTRATION**
- 12. MEDICAL EXAMINATIONS**
- 13. INCIDENT REPORTING AND INVESTIGATION**
- 14. SUBCONTRACTORS**
- 15. SECURITY AND ACCESS**
- 16. FIRE PRECAUTIONS AND FACILITIES**
- 17. ABLUTION FACILITIES**
- 18. HYGIENE AND CLEANLINESS**
- 19. NO NUISANCE**
- 20. INTOXICATION NOT ALLOWED**
- 21. PERSONAL PROTECTIVE EQUIPMENT**
- 22. PLANT, MACHINERY AND EQUIPMENT**
- 23. NO USAGE OF EMPLOYER'S EQUIPMENT**
- 24. TRANSPORT**
- 25. CLARIFICATION**
- 26. DURATION OF AGREEMENT**
- 27. NON COMPLINCE**
- 28. HEADING**

PREAMBLE

WHEREAS section 37(1) & (2) of the Occupational Health and Safety Act No 85 of 1993 ("the Act") requires that parties have an agreement in writing to ensure compliance by a mandatory in line with the provisions of the Act.

AND WHEREAS Transnet SOC Ltd requires the services of the Contractors to execute certain projects within its workshops.

AND WHEREAS TRANSNET SOC LTD can be better served by Contractors who have the infrastructure, specialist employees and expertise to execute such projects at the highest level of efficiency on short notice.

NOW THEREFORE the parties agree as follows;

1. DEFINITIONS

For the purpose of this agreement, unless the context indicates otherwise, the following definitions are set out for the terms indicated:

- 1.1 "Act" means the Occupational Health and Safety Act No 85 of 1993;
- 1.2 "Agreement" means this Mandatory agreement;
- 1.3 "Contractor " means the Mandatory;
- 1.4 "COID Act" means the Compensation for Occupational Injuries and Diseases Act No 130 of 1993.
- 1.5 "Effective Date" means the date of signature of this Agreement by the last party signing hereto;
- 1.6 "Employer" refers to TRANSNET SOC LTD;
- 1.7 "Mandatory" means an agent, Contractor or sub-contractor for work, but without derogating from the status in his own right as an employer or user;
- 1.8 "Parties" means TRANSNET SOC LTD and the Contractor, and "Party" shall mean either one of them, as the context indicates;
- 1.9 "Principal Contract" means the appointed contractor whereby such contractor has to provide goods and or services to TRANSNET SOC LTD.
- 1.10 "Regulations" means regulations promulgated in terms of the relevant legislation.
- 1.11 "Section" means the relevant section of the Occupational Health and Safety Act No 85 of 1993
- 1.12 "Services" means the services to be provided by the Contractor to TRANSNET SOC LTD.
- 1.13 "TRANSNET SOC LTD" means Transnet Group and all its operating divisions and Specialist units with (Registration No. **1990/000900/30**), a public company incorporated in accordance with the company laws of the Republic of South Africa;

2. INTERPRETATION

- 2.1 Clause headings in this Agreement are included for ease of reference only and do not form part of this Agreement for the purposes of interpretation or for any other purpose. No provision shall be construed against or interpreted to the disadvantage of either Party hereto by reason of such Party having or being deemed to have structured or drafted such provision.
- 2.2 Any term, word or phrase used in this Agreement, other than those defined under the clause heading "Definitions" shall be given its plain English meaning, and those terms, words, acronyms, and phrases used in this Agreement will be interpreted in accordance with the generally accepted meanings accorded thereto.
- 2.3 A reference to the singular incorporates a reference to the plural and vice versa.
- 2.4 A reference to natural persons incorporates a reference to legal persons and vice versa.
- 2.5 A reference to a particular gender incorporates a reference to the other gender.

3. REPORTING

- 3.1 The Mandatary and/or his designated person appointed in terms of Section 16(2) of the Occupational Health and Safety Act 85 of 1993 ("the OHS Act") shall report to the Risk Manager and/or a Project Manager and/or a representative designated by the Employer prior to commencing the work at the premises of the Employer.

4. WARRANTY OF COMPLIANCE

- 4.1 In terms of this Agreement the Mandatary warrants that he agrees to any of the arrangements and procedures as prescribed by the Employer and as provided for in terms of Section 37(2) of the OHS Act for the purposes of compliance with the OHS Act.
- 4.2 The Mandatary further warrants that he and/or his employees undertake to maintain such compliance with the OHS Act. Without derogating from the generality of the above, nor from the provisions of the said Agreement, the Mandatary shall ensure that the clauses as hereunder described are at all times adhered to by himself and his employees.
- 4.3 The Mandatary hereby undertakes to ensure that the health and safety of any other person on the premises is not endangered by the conduct of his activities and that of his employees.

5. APPOINTMENTS AND TRAINING

- 5.1 The Mandatary shall appoint competent persons as per Section 16(2) of the OHS Act. Any such appointed person shall be trained on any occupational health and safety matter and the OHS Act provisions pertinent to the work is to be performed under his responsibility. Copies of any appointments made by the Mandatary shall immediately be provided to the Employer.
- 5.2 The Mandatary shall further ensure that all his employees are trained on the health and safety aspects relating to the work to be done on the premises of the Employer and that they understand the hazards associated with such work being carried out on the premises. Without derogating from the foregoing, the Mandatary shall, in particular, ensure that all his users or operators of any materials, machinery or equipment are properly trained in the use of such materials, machinery or equipment.
- 5.3 Notwithstanding the provisions of the above, the Mandatary shall ensure that he, his appointed responsible persons and his employees are at all times familiar with the provisions of the OHS Act, and that they comply with the provisions of the Act.



6. SUPERVISION, DISCIPLINE AND REPORTING

- 6.1 The Mandatary shall ensure that all work performed on the Employer's a premise is done under strict supervision and that no unsafe or unhealthy work practices are permitted. Discipline regarding health and safety matters shall be strictly enforced against any of his employees regarding non-compliance by such employee with any health and safety matters.
- 6.2 The Mandatary shall further ensure that his employees report to him all unsafe or unhealthy work situations immediately after they become aware of such conditions and that he in turn immediately reports these to the Employer and/or his representative.

7. ACCESS TO THE OHS ACT

- 7.1 The Mandatary shall ensure that he has an updated copy of the OHS Act on site at all times and that this is accessible to his appointed responsible persons and employees, save that the parties may make arrangements for the Mandatary and his appointed responsible persons and employees to have access to the Employer's updated copy/copies of the Act.

8. COOPERATION

- 8.1 The Mandatary and/or his responsible persons and employees shall provide full co-operation and information if and when the Employer or his representative inquires into any occupational health and safety issues concerning the Mandatary. It is hereby recorded that the Employer and his representative shall at all times be entitled to make such inquiry.
- 8.2 Without derogating from the generality of the above, the Mandatary and his responsible persons shall make available to the Employer and his representative, on request, all and/or any checklists and inspection registers required to be kept by him in respect of any of his materials, machinery or equipment.

9. WORK PROCEDURES

- 9.1 The Mandatary shall, after having established the dangers associated with the work performed, develop and implement mitigation measures to minimize or eliminate such dangers for the purpose of ensuring a healthy and safe working environment. The Mandatary shall then ensure that his responsible persons and employees are familiar with such mitigation measures.
- 9.2 The Mandatary shall implement any other safe work practices as prescribed by the Employer and shall ensure that his responsible persons and employees are made conversant with such other safe work practices as prescribed by the Employer and that his responsible persons and employees adhere to such safe work practices.
- 9.3 The Mandatary shall ensure that work for which any permit is required by the Employer is not performed by his employees prior to the Employer obtaining such permit from the Mandatary.

10. HEALTH AND SAFETY MEETINGS

- 10.1 If required in terms of the OHS Act, the Mandatary shall establish his own health and safety committee(s) and ensure that his employees, being the committee members, provide health and safety representatives to attend the Employer's health and safety committee meetings.

11. COMPENSATION REGISTRATION

- 11.1 The Mandatary shall ensure that he has a valid proof of registration with the Compensation Commissioner, as required in terms of **COID Act**, and that all payments owing to the Commissioner are discharged. The Mandatary shall further ensure that the cover remain in force while any such employee is present on the premises.



12. MEDICAL EXAMINATIONS

- 12.1 The Mandatary shall ensure that all his employees undergo routine medical examinations and that they are medically fit for the purposes of the work they are to perform.

13. INCIDENT REPORTING AND INVESTIGATION

- 13.1 All incidents referred to in Section 24 of the OHS Act shall be reported by the Mandatary to the Department of Labour and to the Employer. The Employer shall further be provided with copies of any written documentation relating to any incident.
- 13.2 The Employer retains an interest in the reporting of any incident as described above as well as in any formal investigation and/or inquiry conducted in terms of section 32 of the OHS-Act into such incident.

14. SUBCONTRACTORS

- 14.1 The Mandatary shall notify the Employer of any subcontractor he may wish to perform work on his behalf on the Employer's premises. It is hereby recorded that all the terms and provisions contained in

this clause shall be equally binding upon the subcontractor prior to the subcontractor commencing with the work. Without derogating from the generality of this paragraph:

- 14.1.1 The Mandatary shall ensure that training as discussed under appointments and training, is provided prior to the subcontractor commencing work on the Employer's premises.
- 14.1.2 The Mandatary shall ensure that work performed by the subcontractor is done under his strict supervision, discipline and reporting.
- 14.1.3 The Mandatary shall inform the Employer of any health and safety hazards and/or issue that the subcontractor may have brought to his attention.
- 14.1.4 The Mandatary shall inform the Employer of any difficulty encountered regarding compliance by the subcontractor with any health and safety instruction, procedure and/or legal provision applicable to the work the subcontractor performs on the Employer's premises.

15. SECURITY AND ACCESS

- 15.1 The Mandatary and his employees shall enter and leave the premises only through the main gate(s) and/or checkpoint(s) designated by the Employer. The Mandatary shall ensure that employees observe the security rules of the Employer at all times and shall not permit any person who is not directly associated with the work from entering the premises.
- 15.2 The Mandatary and his employees shall not enter any area of the premises that is not directly associated with their work.
- 15.3 The Mandatary shall ensure that all materials, machinery or equipment brought by him onto the premises are recorded at the main gate(s) and/or checkpoint(s). Failure to do this may result in a refusal by the Employer to allow the materials, machinery or equipment to be removed from the Employer's premises.

16. FIRE PRECAUTIONS AND FACILITIES

- 16.1 The Mandatary shall ensure that an adequate supply of fire-protection and first-aid facilities are provided for the work to be performed on the Employer's premises, save that the Parties may mutually make arrangements for the provision of such facilities.



- 16.2 The Mandatary shall further ensure that all his employees are familiar with fire precautions at the premises, which includes fire-alarm signals and emergency exits, and that such precautions are adhered to.

17. ABLUTION FACILITIES

- 17.1 The Mandatary shall ensure that an adequate supply of ablution facilities are provided for his employees performing work on the Employer's premises, save that the parties may mutually make arrangements for the provision of such facilities.

18. HYGIENE AND CLEANLINESS

- 18.1 The Mandatary shall ensure that the work site and surround area is at all times maintained to the reasonably practicable level of hygiene and cleanliness. In this regard, no loose materials shall be left lying about unnecessarily and the work site shall be cleared of waste material regularly and on completion of the work.

19. NO NUISANCE

- 19.1 The Mandatary shall ensure that neither he nor his employees undertake any activity that may cause environmental impairment or constitute any form of nuisance to the Employer and/or his surroundings.
- 19.2 The Mandatary shall ensure that no hindrance, hazard, annoyance or inconvenience is inflicted on the Employer, another Mandatary or any tenants. Where such situations are unavoidable, the Mandatary shall give prior notice to the Employer.

20. INTOXICATION NOT ALLOWED

- 20.1 No intoxicating substance of any form shall be allowed on site. Any person suspected of being intoxicated shall not be allowed on the site. Any person required to take medication shall notify the relevant responsible person thereof, as well as the potential side effects of the medication.

21. PERSONAL PROTECTIVE EQUIPMENT

- 21.1 The Mandatary shall ensure that his responsible persons and employees are provided with adequate personal protective equipment (PPE) for the work they may perform and in accordance with the requirements of General Safety Regulation 2 (1) of the OHS Act. The Mandatary shall further ensure that his responsible persons and employees wear the PPE issued to them at all material times.

22. PLANT, MACHINERY AND EQUIPMENT

- 22.1 The Mandatary shall ensure that all the plant, machinery, equipment and/or vehicles he may wish to utilize on the Employer's premises is/are at all times of sound order and fit for the purpose for which it/they is/are attended to, and that it/they complies/comply with the requirements of Section 10 of the OHS Act.
- 22.2 In accordance with the provisions of Section 10(4) of the OHS Act, the Mandatary hereby assumes the liability for taking the necessary steps to ensure that any article or substance that it erects or installs at the premises, or manufactures, sells or supplies to or for the Employer, complies with all the prescribed requirements and will be safe and without risks in terms of health and safety when properly used.

23. NO USAGE OF THE EMPLOYER'S EQUIPMENT

- 23.1 The Mandatary hereby acknowledges that his employees are not permitted to use any materials, machinery or equipment of the Employer unless the prior written consent of the Employer has been obtained, in which case the Mandatary shall ensure that only those persons authorized to make use of such materials, machinery or equipment, have access thereto.

**24. TRANSPORT**

- 24.1 The Mandatary shall ensure that all road vehicles used on the premises are in a roadworthy condition and are licensed and insured. The Mandatary shall ensure that all drivers shall have relevant and valid driving licenses and the Mandatary shall ensure that no vehicle/s shall carry passengers unless it is specifically designed to do and that all drivers shall adhere to the speed limits and road signs on the premises at all times.
- 24.2 In the event that any hazardous substances are to be transported on the premises, the Mandatary shall ensure that the requirements of the Hazardous Substances Act 15 of 1973 are complied with fully all times.

25. CLARIFICATION

- 25.1 In the event that the Mandatary requires clarification of any of the terms or provisions of this Agreement, he should take the necessary steps to contact the Risk Manager of the Employer to obtain such clarification.

26. DURATION OF AGREEMENT

- 26.1 This Agreement shall remain in force for the duration of the work to be performed by the Mandatary and/or while any of the Mandatary's employees are present on the Employer's premises.

27. NON COMPLIANCE WITH THE AGREEMENT

- 27.1 If the Mandatary fails to comply with any provisions of this Agreement, the Employer shall be entitled to give the mandatory 7 (seven) days written notice to remedy such non-compliance and if the Mandatary fails to comply with such notice, then the Employer shall forthwith be entitled but not obliged, without prejudice to any other rights or remedies which the mandatory may have in law,
- 271.1 to suspend the main Agreement; or
- 27.1.2 To claim immediate performance and/or payment of such obligations.
- 27.2 Should mandatory continue to breach the contract on three occasions, then the Employer is authorised to suspend the main contract without complying with the condition stated in the clause above.

28. HEADINGS

The headings as contained in this Agreement are for reference purposes only and shall not be construed as having any interpretative value in them or as giving any indication as to the meaning of the contents of the paragraphs contained in this Agreement.



Transnet Freight Rail

Contract Number: SIG20030CIDB (HOAC-HO-34780)

Description of Works: Renovation of Main General Buildings (GB CIBD) at various Transnet Freight Rail Depots across Eastern Region for a period of 06 Months. **(Koedoespoort)**

Thus done and signed

at _____ on the _____ day of _____ 201__

For and on behalf of the Employer

Witnesses:

1. _____

2. _____

at _____ on the _____ day of _____ 201__

for and on behalf of the Mandatary

Witnesses:

3. _____

4. _____

TRANSNET



Transnet SOC Limited Registration Number 1990/00900/06

TRANSNET SPECIFICATION

E7/1 - SPECIFICATION FOR GENERAL WORK AND WORKS ON, OVER, UNDER OR ADJACENT TO RAILWAY LINES AND NEAR HIGH VOLTAGE EQUIPMENT







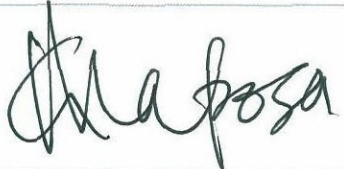

(This specification shall be used in network operator contracts)

Circulation Not Restricted

© This document as a whole is protected by copyright. The information herein is the sole property of Transnet SOC Ltd. It may not be used, disclosed or reproduced in part or in whole in any manner whatsoever, except with the written permission of and in a manner permitted by the proprietors.

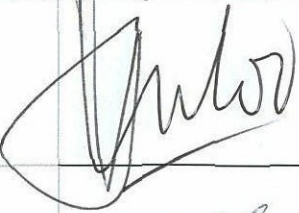
(This page not to be issued with contract)

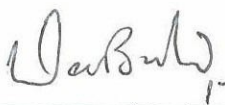
**SPECIFICATION FOR GENERAL WORK AND WORKS ON, OVER, UNDER OR
ADJACENT TO RAILWAY LINES AND NEAR HIGH VOLTAGE EQUIPMENT**

Author:	Project Manager Capital Program (Electrical)	G. Maposa	
Approved:	Senior Engineer Infra Engineering (Train Authorisation Systems)	J. van den Berg	
"	Principal Engineer Infra Engineering (Track)	M. Marutla	
"	Principal Engineer Infra Engineering (Structures)	J. Homan	
"	Principal Engineer Infra Engineering (Electrical)	J. Vosloo	
"	Principal Engineer Technology Management (Electrical)	W. Coetzee	
"	Chief Engineer Transport Telecoms	D. Botha	 17 June 11
Authorised:	Chief Engineer Infrastructure Engineering	J. van Aardt	 2011/06/30

Date:

May 2011

(This page not to be issued with contract)

TRANSNET



Transnet SOC Limited Registration Number 1990/00900/06

TRANSNET SPECIFICATION

E7/1 - SPECIFICATION FOR GENERAL WORK AND WORKS ON, OVER, UNDER OR ADJACENT TO RAILWAY LINES AND NEAR HIGH VOLTAGE EQUIPMENT

(This specification shall be used in network operator contracts)

Circulation Not Restricted

© This document as a whole is protected by copyright. The information herein is the sole property of Transnet SOC Ltd. It may not be used, disclosed or reproduced in part or in whole in any manner whatsoever, except with the written permission of and in a manner permitted by the proprietors.

CONTENTS

<u>CLAUSE</u>	<u>HEADING</u>	<u>PAGE</u>
1.0	SCOPE	3
2.0	DEFINITIONS	3
PART A - GENERAL SPECIFICATION		
3.0	AUTHORITY OF OFFICERS OF TRANSNET	4
4.0	CONTRACTOR'S REPRESENTATIVES AND STAFF	4
5.0	OCCUPATIONS AND WORK PERMITS	4
6.0	SPEED RESTRICTIONS AND PROTECTION	5
7.0	ROADS ON THE NETWORK OPERATOR'S PROPERTY	5
8.0	CLEARANCES	5
9.0	STACKING OF MATERIAL	5
10.0	EXCAVATION, SHORING, DEWATERING AND DRAINAGE	5
11.0	FALSEWORK FOR STRUCTURES	6
12.0	PILING	6
13.0	UNDERGROUND SERVICES	6
14.0	BLASTING AND USE OF EXPLOSIVES	6
15.0	RAIL TROLLEYS	7
16.0	SIGNAL TRACK CIRCUITS	7
17.0	PENALTY FOR DELAYS TO TRAINS	7
18.0	SURVEY BEACONS AND PEGS	7
19.0	TEMPORARY LEVEL CROSSINGS	8
20.0	COMPLETION OF THE WORKS	8
21.0	PROTECTION OF PERSONS AND PROPERTY	9
22.0	INTERFERENCE WITH THE NETWORK OPERATOR'S ASSETS AND WORK ON OPEN LINES	10
23.0	ACCESS, RIGHTS-OF-WAY AND CAMPSITES	10
24.0	SUPERVISION	10
25.0	HOUSING OF EMPLOYEES	10
26.0	OPTICAL FIBRE CABLE ROUTES	10
PART B - ADDITIONAL SPECIFICATION FOR WORK NEAR HIGH-VOLTAGE ELECTRICAL EQUIPMENT		
27.0	GENERAL	11
28.0	WORK ON BUILDINGS OR FIXED STRUCTURES	11
29.0	WORK DONE ON OR OUTSIDE OF ROLLING STOCK, INCLUDING LOADING AND UNLOADING	11
30.0	USE OF EQUIPMENT	12
31.0	CARRYING AND HANDLING MATERIAL AND EQUIPMENT	12
32.0	PRECAUTIONS TO BE TAKEN WHEN ERECTING OR REMOVING POLES, ANTENNAE AND TREES ETC.	12
33.0	USE OF WATER	13
34.0	USE OF CONSTRUCTION PLANT	13
35.0	WORK PERFORMED UNDER DEAD CONDITIONS UNDER COVER OF A WORK PERMIT	13
36.0	TRACTION RETURN CIRCUITS IN RAILS	13
37.0	HIGH-VOLTAGE ELECTRICAL EQUIPMENT NOT MAINTAINED AND/OR OPERATED BY THE NETWORK OPERATOR	14

1.0 SCOPE

- 1.1 This specification covers the network operator's requirements for general work and works on, over, under or adjacent to railway lines and near high voltage equipment.

2.0 DEFINITIONS

The following definitions shall apply:

"Authorised Person" - A person whether an employee of the network operator or not, who has been specially authorised to undertake specific duties in terms of Transnet' publication Electrical Safety Instructions, and who holds a certificate or letter of authority to that effect.

"Barrier" Any device designed to restrict access to "live" high-voltage electrical equipment.

"Bond" - A short conductor installed to provide electrical continuity.

"Contractor" - Any person or organisation appointed by the network operator to carry out work on its behalf.

"Contract Supervisor" - The person or juristic person appointed by the network operator from time to time as the Contract Supervisor, to administer the Contractor's performance and execution of the Works according to the powers and rights held by and obligations placed upon the Contract Supervisor in terms of the Contract.

"Dead" - Isolated and earthed.

"Electrical Officer (Contracts)" - The person appointed in writing by the Project Manager in terms of this specification as the person who shall be consulted by the Contractor in all electrical matters to ensure that adequate safety precautions are taken by the Contractor.

"Executive Officer" - The person appointed by the network operator from time to time as the Executive Officer to act according to the rights and powers held by and obligations placed upon him in terms of the Contract.

"High-Voltage" - A voltage normally exceeding 1000 volts.

"Live" - A conductor is said to be "live" when it is at a potential different from that of the earth or any other conductor of the system of which it forms a part.

"Near" - To be in such a position that a person's body or the tools he is using or any equipment he is handling may come within 3 metres of "live" exposed high-voltage electrical equipment.

"Occupation" - An authorisation granted by the network operator for work to be carried out under specified conditions on, over, under or adjacent to railway lines.

"Occupation Between Trains" - An occupation during an interval between successive trains.

"Optical Fibre Cable" - Buried or suspended composite cable containing optical fibres used in:

- telecommunication networks for transmission of digital information and
- safety sensitive train operations systems.

"Project Manager" – As defined in the special conditions of the contract. The person or juristic person appointed by the network operator from time to time as the Project Manager, to administer the Contract according to the powers and rights held by and obligations placed upon him in terms of the Contract.

"Responsible Representative" - The responsible person in charge, appointed by a contractor, who has undergone specific training (and holds a certificate) to supervise (general or direct) staff under his control who perform general work or to work on, over, under or adjacent to railway lines and in the vicinity of high-voltage electrical equipment.

"Total Occupation" - An occupation for a period when trains are not to traverse the section of line covered by the occupation.

"Work on" - Work undertaken on or so close to the equipment that the specified working clearances to the "live" equipment cannot be maintained.

"Work Permit" - A combined written application and authority to proceed with work on or near dead electrical equipment.

"Works" – The contractual intent for the work to be done as defined in the contract at a defined work site.

PART A - GENERAL SPECIFICATION**3.0 AUTHORITY OF OFFICERS OF TRANSNET**

- 3.1 The Contractor shall co-operate with the officers of the network operator and shall comply with all instructions issued and restrictions imposed with respect to the Works which bear on the existence and operation of the network operator's railway lines and high-voltage equipment.
- 3.2 Without limiting the generality of the provisions of clause 3.1, any duly authorised representative of the network operator, having identified himself, may stop the work if, in his opinion, the safe passage of trains or the safety of the network operator's assets or any person is affected. **CONSIDERATIONS OF SAFETY SHALL TAKE PRECEDENCE OVER ALL OTHER CONSIDERATIONS.**

4.0 CONTRACTOR'S REPRESENTATIVES AND STAFF

- 4.1 The Contractor shall nominate Responsible Representatives of whom at least one shall be available at any hour for call-out in cases of emergency. The Contractor shall provide the Contract Supervisor with the names, addresses and telephone numbers of the representatives.
- 4.2 The Contractor guarantees that he has satisfied himself that the Responsible Representative is fully conversant with this specification and that he shall comply with all his obligations in respect thereof.
- 4.3 The Contractor shall ensure that all contractor staff receives relevant awareness, educational and competence training regarding safety as prescribed.

5.0 OCCUPATIONS AND WORK PERMITS

- 5.1 Work to be done during total occupation or during an occupation between trains or under a work permit shall be done in a manner decided by the Contract Supervisor and at times to suit the network operator requirements.
- 5.2 The Contractor shall organise the Works in a manner which will minimise the number and duration of occupations and work permits required.
- 5.3 The network operator will not be liable for any financial or other loss suffered by the Contractor arising from his failure to complete any work scheduled during the period of an occupation or work permit.
- 5.4 The Contractor shall submit to the Contract Supervisor, in writing, requests for occupations or work permits together with details of the work to be undertaken, at least 21 days before they are required. The network operator does not undertake to grant an occupation or work permit for any particular date, time or duration.
- 5.5 The network operator reserves the right to cancel any occupation or work permit at any time before or during the period of occupation or work permit. If, due to cancellation or change in date or time, the Contractor is not permitted to start work under conditions of total occupation or work permit at the time arranged, all costs caused by the cancellation shall be born by the Contractor except as provided for in clauses 5.6 to 5.8.
- 5.6 When the Contractor is notified less than 2 hours before the scheduled starting time that the occupation or work permit is cancelled, he may claim reimbursement of his direct financial losses caused by the loss of working time up to the time his labour and plant are employed on other work, but not exceeding the period of the cancelled occupation or work permit.
- 5.7 When the Contractor is notified less than 2 hours before the scheduled starting time, or during an occupation or work permit, that the duration of the occupation or work permit is reduced, he may claim reimbursement of his direct financial losses caused by the loss of working time due to the reduced duration of the occupation or work permit.
- 5.8 Reimbursement of the Contractor for any loss of working time in terms of clause 5.6 and 5.7, shall be subject to his claims being submitted within 14 days of the event with full details of labour and plant involved, and provided that the Contract Supervisor certifies that no other work on which the labour and plant could be employed was immediately available.
- 5.9 Before starting any work for which an occupation has been arranged, the Contractor shall obtain from the Contract Supervisor written confirmation of the date, time and duration of the occupation.
- 5.10 Before starting any work for which a work permit has been arranged, the Responsible Representative shall read and sign portion C of the Work Permit, signifying that he is aware of the work boundaries within which work may be undertaken. After the work for which the permit was granted has been completed, or when the

work permit is due to be terminated, or if the permit is cancelled after the start, the same person who signed portion C shall sign portion D of the Work Permit, thereby acknowledging that he is aware that the electrical equipment is to be made "live". The Contractor shall advise all his workmen accordingly.

6.0 SPEED RESTRICTIONS AND PROTECTION

- 6.1 When speed restrictions are imposed by the network operator because of the Contractor's activities, the Contractor shall organise and carry out his work so as to permit the removal of the restrictions as soon as possible.
- 6.2 When the Contract Supervisor considers protection to be necessary the Contractor shall, unless otherwise agreed, provide all protection including flagmen, other personnel and all equipment for the protection of the network operator's and the Contractor's personnel and assets, the public and including trains.
- 6.2.1 The network operator will provide training free of charge of the Contractor's flagmen and other personnel performing protection duties. The Contractor shall consult with the Contract Supervisor, whenever he considers that protection will be necessary, taking into account the minimum permissible clearances set out in the Manual for Track Maintenance (Document no. BBB0481):
- Drawing no. BE-97 Sheet 1: Horizontal Clearances: 1065mm gauge (Annexure 1 sheet 1)
 - Drawing no. BE-97 Sheet 2: Vertical Clearances: 1065mm gauge (Annexure 1 sheet 2)
 - Drawing no. BE-97 Sheet 3: Clearances: Platform (Annexure 1 sheet 3)
 - Drawing no. BE-97 Sheet 5: Clearances: 610mm Gauge (Annexure 1 sheet 5)
- 6.3 The Contractor shall appoint a Responsible Representative to receive and transmit any instruction which may be given by the network operator personnel providing protection.

7.0 ROADS AND ROADS ON THE NETWORK OPERATOR'S PROPERTY

- 7.1 The Contractor shall take every reasonable precaution to prevent damage to any roads or bridges used to obtain access to the site, and shall select routes, use vehicles, and restrict loads so that any extraordinary traffic as may arise from the moving of plant or material to or from the site shall be limited as far as is reasonably possible.
- 7.2 The Contractor shall not occupy or interfere in any way with the free use of any public or private road, right-of-way, path or street unless the Contract Supervisor has obtained the approval of the road authority concerned.

8.0 CLEARANCES

- 8.1 No temporary works shall encroach on the appropriate minimum clearances set out in the Manual for Track Maintenance (Document no. BBB0481):
- Drawing no. BE-97 Sheet 1: Horizontal Clearances: 1065mm gauge (Annexure 1 sheet 1)
 - Drawing no. BE-97 Sheet 2: Vertical Clearances: 1065mm gauge (Annexure 1 sheet 2)
 - Drawing no. BE-97 Sheet 3: Clearances: Platform (Annexure 1 sheet 3)
 - Drawing no. BE-97 Sheet 5: Clearances: 610mm Gauge (Annexure 1 sheet 5)

9.0 STACKING OF MATERIAL

- 9.1 The Contractor shall not stack any material closer than 3m from the centre line of any railway line without prior approval of the Contract Supervisor.

10.0 EXCAVATION, SHORING, DEWATERING AND DRAINAGE

- 10.1 Unless otherwise approved by the Contract Supervisor any excavation adjacent to a railway line shall not encroach on the hatched area shown in Figure 1.

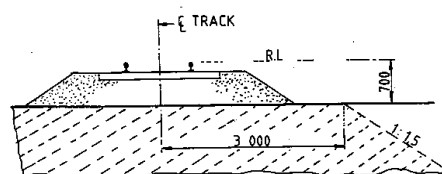

Fig. 1.

- 10.2 The Contractor shall provide, at his own cost any shoring, dewatering or drainage of any excavation unless otherwise stipulated elsewhere in the Contract.
- 10.3 Where required by the Contract Supervisor, drawings of shoring for any excavation under or adjacent to a railway line shall be submitted and permission to proceed, obtained before the excavation is commenced.
- 10.4 The Contractor shall prevent ingress of water to the excavation but where water does enter, he shall dispose of it as directed by the Contract Supervisor.
- 10.5 The Contractor shall not block, obstruct or damage any existing drains either above or below ground level unless he has made adequate prior arrangements to deal with drainage.

11.0 FALSEWORK FOR STRUCTURES

- 11.1 Drawings of falsework for the construction of any structure over, under or adjacent to any railway line shall be submitted to the Contract Supervisor and his permission to proceed obtained before the falsework is erected. Each drawing shall be given a title and a distinguishing number and shall be signed by a registered professional engineer certifying that he has checked the design of the falsework and that the drawings are correct and in accordance with the design.
- 11.2 After the falsework has been erected and before any load is applied, the Contractor shall submit to the Contract Supervisor a certificate signed by a registered professional engineer certifying that he has checked the falsework and that it has been erected in accordance with the drawings. Titles and numbers of the drawings shall be stated in the certificate. Notwithstanding permission given by the Contract Supervisor to proceed, the Contractor shall be entirely responsible for the safety and adequacy of the falsework.

12.0 PILING

- 12.1 The Contract Supervisor will specify the conditions under which piles may be installed on the network operator's property.

13.0 UNDERGROUND SERVICES

- 13.1 No pegs or stakes shall be driven or any excavation made before the Contractor has established that there are no underground services which may be damaged thereby.
- 13.2 Any damage shall be reported immediately to the Contract Supervisor, or to the official in charge at the nearest station, or to the traffic controller in the case of centralised traffic control.

14.0 BLASTING AND USE OF EXPLOSIVES

- 14.1 When blasting within 500m of a railway line, the Contractor shall observe the requirements stipulated in this specification.
- 14.2 No blasting shall be carried out except with the prior written permission of the Contract Supervisor and under such conditions as he may impose.
- 14.3 On electrified lines the Contractor shall also obtain the permission of the Electrical Officer (Contracts) before blasting, and shall give at least 21 days notice of his intention to blast. No blasting shall be done in the vicinity of electrified lines unless a member of the network operator's electrical personnel is present.
- 14.4 The Contractor shall arrange for the supply, transport storage and use of explosives.
- 14.5 The Contractor shall have labour, tools and plant, to the satisfaction of the Contract Supervisor, available on the site to clear immediately any stones or debris deposited on the track or formation by blasting, and to repair any damage to the track or formation immediately after blasting. Repairs to the track shall be carried out only under the supervision of a duly authorised representative of the network operator.
- 14.6 The Contractor shall notify the Contract Supervisor of his intention to blast at least 21 days before the commencement of any blasting operations.
- 14.7 Before any blasting is undertaken, the Contractor and the Contract Supervisor shall jointly examine and measure up any buildings, houses or structures in the vicinity of the proposed blasting to establish the extent of any existing cracking or damage to such structures, etc. The Contractor, shall, subject to the provisions stipulated in the Contract Insurance Policy, make good any deterioration of such buildings, houses, or structures, which, in the opinion of the Contract Supervisor, was directly caused by the blasting.
- 14.8 After completion of the blasting the Contractor shall obtain a written clearance from each landowner in

the vicinity of the blasting operations to the effect that all claims for compensation in respect of damage caused by the blasting operations to their respective properties, have been settled.

- 14.9 The Contractor shall provide proof that he has complied with the provisions of clauses 10.17.1 to 10.17.4 of the Explosives Regulations (Act 26 of 1956 as amended).
- 14.10 Blasting within 500m of a railway line will only be permitted during intervals between trains. A person appointed by the Contract Supervisor, assisted by flagmen with the necessary protective equipment, will be in communication with the controlling railway station.
- Only this person will be authorised to give the Contractor permission to blast, and the Contractor shall obey his instructions implicitly regarding the time during which blasting may take place.
- 14.11 The flagmen described in clause 14.10, where provided by the network operator, are for the protection of trains and the network operator's property only, and their presence does not relieve the Contractor in any manner of his responsibilities in terms of Explosives Act or Regulations, or any obligation in terms of this Contract.
- 14.12 The person described in clause 14.10 will record in a book provided and retained by the network operator, the dates and times:-
- (i) when each request is made by him to the controlling station for permission to blast;
 - (ii) when blasting may take place;
 - (iii) when blasting actually takes place; and
 - (iv) when he advises the controlling station that the line is safe for the passage of trains.
- 14.13 Before each blast the Contractor shall record in the same book, the details of the blast to be carried out. The person appointed by the Contract Supervisor and the person who will do the blasting shall both sign the book whenever an entry described in clause 14.12 is made.

15.0 RAIL TROLLEYS

- 15.1 The use of rail trolleys or trestle trolleys on a railway line for working on high voltage equipment will be permitted only if approved by the Contract Supervisor and under the conditions stipulated by him.
- 15.2 All costs in connection with trolley working and any train protection services requested by the Contractor shall, be borne by the Contractor, unless otherwise agreed.

16.0 SIGNAL TRACK CIRCUITS

- 16.1 Where signal track circuits are installed, the Contractor shall ensure that no material capable of conducting an electrical current makes contact between rails of railway line/lines.
- 16.2 No signal connections on track-circuited tracks shall be severed without the Contract Supervisor's knowledge and consent.

17.0 PENALTY FOR DELAYS TO TRAINS

- 17.1 If any trains are delayed by the Contractor and the Contract Supervisor is satisfied that the delay was avoidable, a penalty will be imposed on the Contractor as stipulated in the contract, for the period and number of trains delayed.

18.0 SURVEY BEACONS AND PEGS

- 18.1 The Contractor shall not on any account move or damage any beacon, bench mark, reference mark, signal or trigonometrical station in the execution of the Works without the written approval of the Contract Supervisor.

Should the Contractor be responsible for any such occurrence, he shall report the circumstances to the Contract Supervisor who will arrange with the Director-General of Surveys for replacement of the beacon or mark at the cost of the Contractor.

- 18.2 The Contractor shall not move or damage any cadastral or mining beacon without the written approval of the Contract Supervisor and before it has been referenced by a registered land surveyor. Any old boundary beacon, which becomes an internal beacon on creation of new boundaries, shall not be moved without the written approval of the Contract Supervisor.

Should the Contractor move or damage any cadastral or mining beacon without authority, he shall be responsible for having it replaced, at his cost, by a land surveyor.

- 18.3 The Contractor shall preserve all pegs and bench marks. Such survey points shall not be removed without the written approval of the Contract Supervisor. Should any peg or benchmark be removed without authority, the Contract Supervisor will arrange for its replacement and the cost will be recovered from the Contractor. No claim will be considered for delay in replacing any such peg or bench mark. Each peg replaced shall be checked by the Contractor.
- 18.4 Where a new boundary has been established, beacons on the fence line shall not be disturbed, and fence posts or anchors may not be placed or excavations made within 0,6 m of any beacon without the prior written approval of the Contract Supervisor.

19.0 TEMPORARY LEVEL CROSSINGS

- 19.1 The Contract Supervisor may, on request of the Contractor, and if necessary for the purpose of execution of the Works, permit the construction of a temporary level crossing over a railway a line at a position approved by the Contract Supervisor and at the Contractor's cost. The period for which the temporary level crossing is permitted will be at the discretion of the Contract Supervisor.
- 19.2 The Contractor will provide protection and supervise the construction of the road over the track(s) and within the railway servitude at the level crossing, as well as the erection of all road signs and height gauges. All cost to be borne by the applicant.

The Contractor shall exercise extreme caution in carrying out this work, especially in respect of damage to tracks, services, overhead power and communications routes and prevent contact with "live" overhead electrical equipment.

Unless otherwise agreed, the Contractor will provide the service deviations or alterations to the network operator's track-, structure-, drainage-, electrical-, telecommunications- and train authorisation systems to accommodate the level crossing.

- 19.3 The Contractor shall take all necessary steps including the provision of gates, locks and, where necessary, watchmen to restrict the use of the temporary level crossing to himself and his employees, his subcontractors and their employees, the staff of the network operator and to such other persons as the Contract Supervisor may permit and of whose identity the Contractor will be advised. If so ordered by the Contract Supervisor, the Contractor shall provide persons to control road traffic using the temporary level crossing. Such persons shall stop all road traffic when any approaching train is within seven hundred and fifty (750) metres of the temporary level crossing, and shall not allow road traffic to proceed over it until the lines are clear.
- 19.4 The Contractor shall maintain the temporary level crossing within the railway servitude in good condition for the period it is in use. A temporary agreement with the road authority to be concluded for the maintenance of the level crossing outside the railway servitude.
- 19.5 When the temporary level crossing is no longer required by the Contractor, or permitted by the network operator, the Contractor shall at his own cost remove it and restore the site and the network operator's track-, structure-, drainage-, electrical-, telecommunications- and train authorisation systems to its original condition. Work over the tracks and within the railway servitude will be supervised by the network operator.

20.0 COMPLETION OF THE WORKS

- 20.1 On completion of the works, the Contractor shall remove all the remaining construction plant and material from the site, other than material which is the property of the network operator, and leave the site in a clean, neat and tidy condition. If material and plant is required for the liability and maintenance period the Contract supervisor must authorise it's retention on site.

21.0 PROTECTION OF PERSONS AND PROPERTY

- 21.1 The Contractor shall provide and maintain all lights, guards, barriers, fencing and watchmen when and where necessary or as required by the Contract Supervisor or by any statutory authority, for the protection of the Works and for the safety and convenience of the public.

Red, yellow, green or blue lights may not be used by the Contractor as they can be mistaken for signals. Red, yellow, green or white flags shall only be used for protection by the Contractor. Within the precincts of a port the Contractor shall obtain the permission of the Port Captain before installing any light.

- 21.2 The Contractor shall take all the requisite measures and precautions during the course of the Works to:
- (i) protect the public and property of the public,
 - (ii) protect the property and workmen of both the network operator and the Contractor,
 - (iii) avoid damage to and prevent trespass on adjoining properties, and
 - (iv) ensure compliance with any instruction issued by the Contract Supervisor or other authorised person, and with any stipulation embodied in the contract documents which affects the safety of any person or thing.
- 21.3 The network operator will provide, at its own cost, protection for the safe working of trains during such operations as the Contract Supervisor may consider necessary. Protection by the network operator for any purpose whatsoever, does not absolve the Contractor of his responsibilities in terms of the Contract.
- 21.4 The Contractor shall take all precautions and appoint guards, watchmen and compound managers for prevention of disorder among and misconduct by the persons employed on the Works and by any other persons, whether employees or not, on the work site and for the preservation of the peace and protection of persons and property in the direct neighbourhood. Any relocation of camps because of disorder shall be at the Contractor's expense.
- 21.5 All operations necessary for the execution of the Works, including the provision of any temporary work and camping sites, shall be carried out so as not to cause veldt fires, ground and environmental pollution, soil erosion or restriction of or interference with streams, furrows, drains and water supplies.
- If the original surface of the ground is disturbed in connection with the Works, it shall be made good by the Contractor to the satisfaction of the land owner, occupier or responsible authority.
- 21.6 The Contractor shall take all reasonable steps to minimise noise and disturbance when carrying out the Works, including work permitted outside normal working hours.
- 21.7 Dumping of waste or excess materials by the Contractor shall, in urban areas, be done under the direction and control of, and at sites made available by the local authority. Dumping outside local authority boundaries shall be done only with the express permission and under the direction and control of the Contract Supervisor.
- 21.8 The Contractor shall comply with environmental protection measures and specifications stipulated by the Contract Supervisor and/or local and environmental authorities.
- 22.0 INTERFERENCE WITH THE NETWORK OPERATOR'S ASSETS AND WORK ON OPEN LINES**
- 22.1 The Contractor shall not interfere in any manner whatsoever with an open line, nor shall he carry out any work or perform any act which affects the security, use or safety of an open line except with the authority of the Contract Supervisor and in the presence of a duly authorised representative of the network operator.
- 22.2 The Contractor shall not carry out any work or operate any plant, or place any material whatsoever nearer than three metres from the centre line of any open line except with the written permission of the Contract Supervisor and subject to such conditions as he may impose.
- 22.3 Care must be taken not to interfere with or damage any services such as overhead wire routes, cables or pipes and optical fibre cable, except as provided for the work specified. The Contractor will be held responsible for any damage to or interruption of such services arising from any act or omission on his part or of any of his employees, or persons engaged by him on the Works. The cost of repairing, replacing or restoring the services, as well as all other costs arising from any damage to services, shall be borne by, and will be recovered from the Contractor.
- 22.4 Authority granted by the Contract Supervisor and the presence of an authorised representative of the network operator in terms hereof, shall not relieve the Contractor of his duty to comply with this specification.
- 23.0 ACCESS, RIGHTS-OF-WAY AND CAMPSITES**
- 23.1 Where entry onto the network operator's property is restricted, permission to enter will be given only for the purpose of carrying out the Works and will be subject to the terms and conditions laid down by the network operator.
- 23.2 The Contractor shall arrange for campsites, workplaces and access thereto as well as for any right-of-

way over private property to the site of the Works, and for access within the boundaries of the network operator's property. The owners of private property to be traversed shall be approached and treated with tact and courtesy by the Contractor, who shall, if necessary, obtain a letter of introduction to such property owners from the Contract Supervisor.

The Contractor shall be responsible for the closing of all gates on roads and tracks used by him or his employees. Except with the prior approval of the Contract Supervisor and the owner or occupier of any private land to be traversed, the Contractor shall not cut, lower, damage, remove or otherwise interfere with any fence or gate which is either on the network operator's property or on private property and which restricts access to the Works. Where such approval has been given, the Contractor shall prevent entry of animals or unauthorised persons onto the network operator's or private property, and shall make the fences safe against trespass at the close of each day's work.

- 23.3 The Contractor shall take all reasonable steps to confine the movement of vehicles and plant to the approved right-of-way to minimise damage to property, crops and natural vegetation.
- 23.4 When access is no longer required, and before completion of the Works, the Contractor shall repair, restore or replace any fence or gate damaged during execution of the Works to the satisfaction of the Contract Supervisor and shall furnish the Contract Supervisor with a certificate signed by the owner and occupier of land over which he has gained access to a campsite, workplace and the Works, certifying that the owner and occupier have no claim against the Contractor or the network operator arising from the Contractor's use of the land. Should the Contractor be unable to obtain the required certificate, he shall report the circumstances to the Contract Supervisor.

24.0 SUPERVISION

- 24.1 The Contract Supervisor will provide overall technical superintendence of the Works, and may direct the Contractor in terms of the provisions of the Contract or in respect of any measures which the Contract Supervisor may require for the operations of the network operator, the safety of trains, property and workmen of the network operator, and for the safety of other property and persons. The Contractor shall carry out the directions of the Contract Supervisor. The superintendence exercised by the Contract Supervisor, including any agreement, approval, refusal or withdrawal of any approval given, shall not relieve the Contractor of any of his duties and liabilities under the Contract, and shall not imply any assumption by the network operator or by the Contract Supervisor of the legal and other responsibilities of the Contractor in carrying out the Works.
- 24.2 The Contract Supervisor may delegate to any deputy or other person, any of his duties or functions under the Contract. On receiving notice in writing of such delegation, the Contractor shall recognise and obey the deputy or person to whom any such duties or functions have been delegated as if he were the Contract Supervisor.
- 24.3 The Contractor shall exercise supervision over the Works at all times when work is performed or shall be represented by an agent having full power and authority to act on behalf of the Contractor. Such agent shall be competent and responsible, and have adequate experience in carrying out work of a similar nature to the Works, and shall exercise personal supervision on behalf of the Contractor. The Contract Supervisor shall be notified in writing of such appointment which will be subject to his approval.
- 24.4 The Contractor or his duly authorised agent shall be available on the site at all times while the Works are in progress to receive the orders and directions of the Contract Supervisor.

25.0 HOUSING OF EMPLOYEES

- 25.1 The Contractor shall, where necessary, make his own arrangements for suitable housing of his employees. Where temporary housing is permitted by the Contract Supervisor on any part of the site, the Contractor shall provide suitable sanitation, lighting and potable water supplies in terms of the requirements of the local authority or the current network operator's specification; Minimum Communal Health Requirements in Areas outside the Jurisdiction of a Local Authority - E.4B, as applicable.
- 25.2 Fouling the area inside or outside the network operator's boundaries shall be prevented. The Contractor will be called upon by the Contract Supervisor to dispose of any foul or waste matter generated by the Contractor.

26.0 OPTICAL FIBRE CABLE ROUTES

- 26.1 The Contractor shall not handle, impact, move or deviate any optical fibre cable without prior approval.
- 26.2 Works that in any way affect the optical fibre cable requires prior approval from the Contract Supervisor

who will determine the work method and procedures to be followed.

PART B - SPECIFICATION FOR WORK NEAR HIGH-VOLTAGE ELECTRICAL EQUIPMENT
27.0 GENERAL

27.1 This specification is based on the contents of Transnet's publication ELECTRICAL SAFETY INSTRUCTIONS, as amended, a copy of which will be made available on loan to the Contractor for the duration of the contract.

These instructions apply to all work near "live" high-voltage equipment maintained and/or operated by the network operator, and the onus rests on the Contractor to ensure that he obtains a copy.

27.2 This specification must be read in conjunction with and not in lieu of the Electrical Safety Instructions.

27.3 The Contractor's attention is drawn in particular to the contents of Part I, Sections 1 and 2 of the Electrical Safety Instructions.

27.4 The Electrical Safety Instructions cover the minimum safety precautions which must be taken to ensure safe working on or near high-voltage electrical equipment, and must be observed at all times. Should additional safety measures be considered necessary because of peculiar local conditions, these may be ordered by and at the discretion of the Electrical Officer (Contracts).

27.5 The Contractor shall obtain the approval of the Electrical Officer (Contracts) before any work is done which causes or could cause any portion of a person's body or the tools he is using or any equipment he is handling, to come within 3 metres of any "live" high-voltage equipment.

27.6 The Contractor shall regard all high-voltage equipment as "live" unless a work permit is in force.

27.7 Safety precautions taken or barriers erected shall comply with the requirements of the Electrical Officer (Contracts), and shall be approved by him before the work to be protected is undertaken by the Contractor. The Contractor shall unless otherwise agreed, bear the cost of the provision of the barriers and other safety precautions required, including the attendance of the network operator's staff where this is necessary.

27.8 No barrier shall be removed unless authorised by the Electrical Officer (Contracts).

28.0 WORK ON BUILDINGS OR FIXED STRUCTURES

28.1 Before any work is carried out or measurements are taken on any part of a building, fixed structure or earthworks of any kind above ground level situated within 3 metres of "live" high-voltage equipment, the Electrical Officer (Contracts) shall be consulted to ascertain the conditions under which the work may be carried out.

28.2 No barrier erected to comply with the requirements of the Electrical Officer (Contracts) shall be used as temporary staging or shuttering for any part of the Works.

28.3 The shuttering for bridge piers, abutments, retaining walls or parapets adjacent to or over any track may be permitted to serve as a barrier, provided that it extends at least 2,5 metres above any working level in the case of piers, abutments and retaining walls and 1,5 metres above any working level in the case of parapets.

29.0 WORK DONE ON OR OUTSIDE OF ROLLING STOCK, INCLUDING LOADING OR UNLOADING

29.1 No person may stand, climb or work, whilst on any platform, surface or foothold:

29.1.1 higher than the normal unrestricted access way, namely -

29.1.1.1 external walkways on diesel, steam and electric locomotives, steam heat vans, etc. and

29.1.1.2 walkways between coaches and locomotives.

29.1.2 of restricted access ways in terms of the Electrical Safety Instructions namely -

29.1.2.1 the floor level of open wagons

29.1.2.2 external walkways or decks of road-rail vehicles, on-track maintenance machines and material trains.

29.1.3 Unauthorised staff working on these platforms must be directly supervised by duly authorised persons in terms of clause 607.1.3 of the Electrical Safety Instructions. These persons must attend the relevant electrical safety module training. A letter of training must then be issued by an accredited training authority. A Category C Certificate of Authority must be obtained from the

local depot examining officer.

- 29.2 When in the above positions no person may raise his hands or any equipment he is handling above his head.
- 29.3 In cases where the Contractor operates his own rail mounted equipment, he shall arrange for the walkways on this plant to be inspected by the Electrical Officer (Contracts) and approved, before commencement of work.
- 29.4 The handling of long lengths of material such as metal pipes, reinforcing bars, etc should be avoided, but if essential they shall be handled as nearly as possible in a horizontal position below head height.
- 29.5 The Responsible Representative shall warn all persons under his control of the danger of being near "live" high-voltage equipment, and shall ensure that the warning is fully understood.
- 29.6 Where the conditions in clauses 30.1 to 30.4 cannot be observed the Electrical Officer (Contracts), shall be notified. He will arrange for suitable Safety measures to be taken. The Electrical Officer (Contracts), may in his discretion and in appropriate circumstances, arrange for a suitable employee of the Contractor to be specially trained by the network operator and at the Contractor's cost, as an Authorised Person to work closer than 3 metres from "live" overhead conductors and under such conditions as may be imposed by the senior responsible electrical engineer of the network operator.

30.0 USE OF EQUIPMENT

30.1 Measuring Tapes and Devices

- 30.1.1 Measuring tapes may be used near "live" high-voltage equipment provided that no part of any tape or a person's body comes within 3 metres of the "live" equipment.
- 30.1.2 In windy conditions the distance shall be increased to ensure that if the tape should fall it will not be blown nearer than 3 metres from the "live" high-voltage equipment.
- 30.1.3 Special measuring devices longer than 2 metres such as survey sticks and rods may be used if these are of non-conducting material and approved by the responsible Electrical Engineer of the network operator, but these devices must not be used within 3 metres of "live" high-voltage equipment in rainy or wet conditions.
- 30.1.4 The assistance of the Electrical Officer (Contracts) shall be requested when measurements within the limits defined in clauses 31.1.1 to 31.1.3 are required.
- 30.1.5 The restrictions described in 31.1.1 to 31.1.3 do not apply on a bridge deck between permanent parapets nor in other situations where a barrier effectively prevents contact with the "live" high-voltage equipment.

30.2 Portable Ladders

- 30.2.1 Any type of portable ladder longer than 2 metres may only be used near "live" high-voltage equipment under the direct supervision of the Responsible Representative. He shall ensure that the ladder is always used in such a manner that the distance from the base of the ladder to any "live" high-voltage equipment is greater than the fully extended length of the ladder plus 3 metres. Where these conditions cannot be observed, the Electrical Officer (Contracts) shall be advised, and he will arrange for suitable safety measures to be taken.

31.0 CARRYING AND HANDLING MATERIAL AND EQUIPMENT

- 31.1 Pipes, scaffolding, iron sheets, reinforcing bars and other material which exceeds 2 metres in length shall be carried completely below head height near "live" high-voltage equipment. For maximum safety such material should be carried by two or more persons so as to maintain it as nearly as possible in a horizontal position. The utmost care must be taken to ensure that no part of the material comes within 3 metres of any "live" high-voltage equipment.
- 31.2 Long lengths of wire or cable shall never be run out in conditions where a part of a wire or cable can come within 3 metres of any "live" high-voltage equipment unless the Electrical Officer (Contracts) has been advised and has approved appropriate safety precautions.
- 31.3 The presence of overhead power lines shall always be taken account of especially when communications lines or cables or aerial cables, stay wires, etc. are being erected above ground level.

32.0 PRECAUTIONS TO BE TAKEN WHEN ERECTING OR REMOVING POLES, ANTENNAE, TREES ETC.

- 32.1 A pole may be handled for the purpose of erection or removal near high-voltage equipment under the following conditions:

(i) If the distance between the point at which the pole is to be erected or removed and the nearest "live" high-voltage equipment is more than the length of the pole plus 3 metres, the work shall be supervised by the Responsible Representative.

(ii) If the distance described in (i) is less than the length of the pole plus 3 metres, the Electrical Officer (Contracts) shall be consulted to arrange for an Authorised Person to supervise the work and to ensure that the pole is earthed where possible. The pole shall be kept in contact with the point of erection, and adequate precautions shall be taken to prevent contact with "live" high-voltage equipment.

32.2 The cost of supervision by an Authorised Person and the provision of earthing shall, unless otherwise agreed, be borne by the Contractor.

32.3 The provisions of clauses 33.1 and 33.2 shall also apply to the erection or removal of columns, antennae, trees, posts, etc.

33.0 USE OF WATER

33.1 No water shall be used in the form of a jet if it can make contact with any "live" high-voltage equipment or with any person working on such equipment.

34.0 USE OF CONSTRUCTION PLANT

34.1 "Construction plant" entails all types of plant including cranes, piling frames, boring machines, excavators, draglines, dewatering equipment and road vehicles with or without lifting equipment.

34.2 When work is being undertaken in such a position that it is possible for construction plant or its load to come within 3 metres of "live" high-voltage equipment, the Electrical Officer (Contracts) shall be consulted. He will arrange for an Authorised Person to supervise the work and to ensure that the plant is adequately earthed. The Electrical Officer (Contracts) will decide whether further safety measures are necessary.

34.3 The cost of any supervision by an Authorised Person and the provision of earthing shall, unless otherwise agreed, be borne by the Contractor.

34.4 When loads are handled by cranes, non-metallic rope hand lines shall be used, affixed to such loads so as to prevent their swinging and coming within 3 metres of "live" high-voltage equipment.

34.5 Clauses 35.1 to 35.4 shall apply *mutatis mutandis* to the use of maintenance machines of any nature.

35.0 WORK PERFORMED UNDER DEAD CONDITIONS UNDER COVER OF A WORK PERMIT

35.1 If the Responsible Representative finds that the work cannot be done in safety with the high-voltage electrical equipment "live", he shall consult the Electrical Officer (Contracts) who will decide on the action to be taken.

35.2 If a work permit is issued the Responsible Representative shall-

(i) before commencement of work ensure that the limits within which work may be carried out have been explained to him by the Authorised Person who issued the permit to him, and that he fully understands these limits.

(ii) sign portion C of the permit before commencement of work;

(iii) explain to all persons under his control the limits within which work may be carried out, and ensure that they fully understand these limits;

(iv) care for the safety of all persons under his control whilst work is in progress; and

(v) withdraw all personnel under his control from the equipment on completion of the work before he signs portion D of the work permit.

36.0 TRACTION RETURN CIRCUITS IN RAILS

36.1 DANGEROUS CONDITIONS CAN BE CREATED BY REMOVING OR SEVERING ANY BOND.

36.2 Broken rails with an air gap between the ends, and joints at which fishplates are removed under "broken bond" conditions, are potentially lethal. The rails on either side of an air gap between rail ends on electrified lines shall not be touched simultaneously until rendered safe by the network operator personnel.

36.3 The Contractor shall not break any permanent bonds between rails or between rails and any structure. He shall give the Contract Supervisor at least 7 days written notice when removal of such bonds is necessary.

36.4 No work on the track which involves interference with the traction return rail circuit either by cutting or removing the rails, or by removal of bonds shall be done unless the Electrical Officer (Contracts) is consulted. He will take such precautions as may be necessary to ensure continuity of the return circuit before permitting the work to be commenced.

37.0 HIGH-VOLTAGE ELECTRICAL EQUIPMENT NOT MAINTAINED AND/OR OPERATED BY THE NETWORK OPERATOR

Where the work is undertaken on or near high-voltage electrical equipment which is not maintained and/or operated by the network operator, the Occupational Health and Safety Act No. 85 of 1993, and Regulations and Instructions, or the Mines Health and Safety Act (Act 29 of 1996), shall apply.

Such equipment includes:-

- (i) Eskom and municipal equipment;
- (ii) The Contractor's own power supplies; and
- (iii) Electrical equipment being installed but not yet taken over from the Contractor.

END

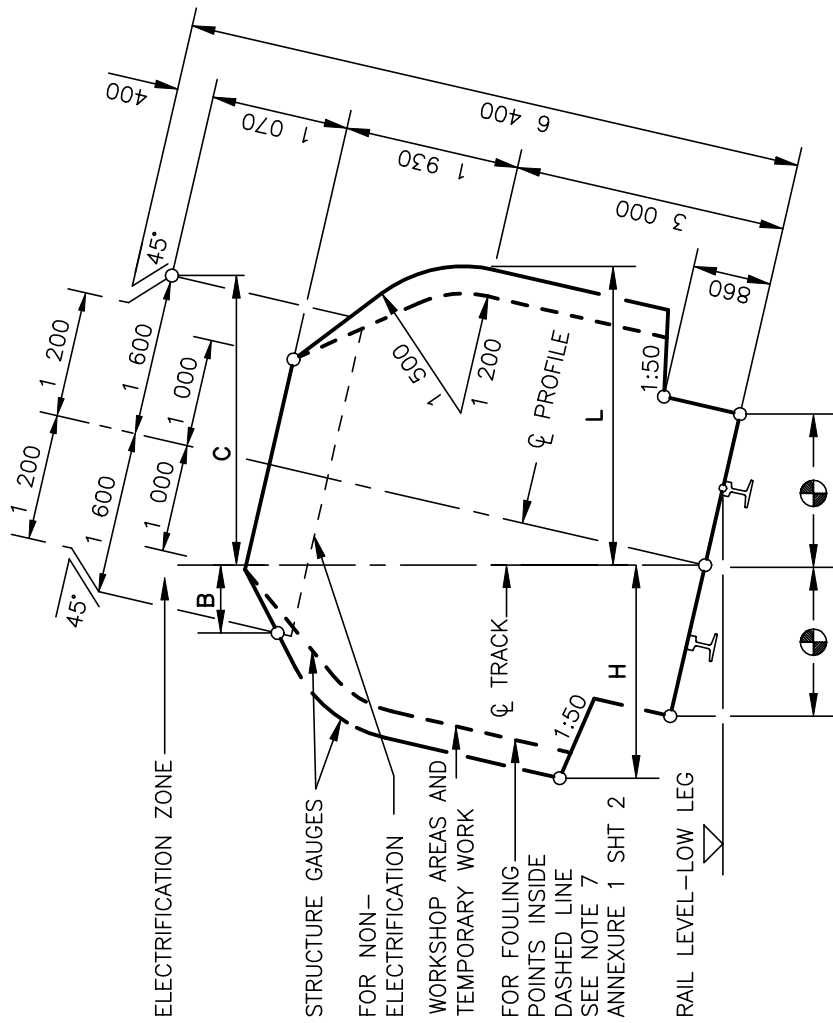

RADIUS (m)	WITH CANT		NO CANT	
	H (mm)	L (mm)	H & L	C (mm)
90	2 730	3 090	2 780	2 100
100	2 700	3 030	2 750	2 050
120	2 650	2 970	2 700	2 010
140	2 620	2 920	2 660	1 990
170	2 590	2 870	2 630	1 970
200	2 570	2 820	2 600	1 950
250	2 550	2 790	2 580	1 920
300	2 540	2 760	2 560	1 900
350	2 530	2 730	2 540	1 890
400	2 520	2 710	2 530	1 875
500	2 510	2 680	2 520	1 850
600	2 500	2 660	2 510	1 830
800	2 490	2 620	2 500	1 790
1 000	2 480	2 600	2 490	1 760
1 200	2 480	2 580	2 490	1 730
1 500	2 480	2 550	2 480	1 700
2 000	2 480	2 500	2 480	1 660
3 000	2 470	2 470	2 470	1 600
>5 000	2 460	2 460	2 460	1 600

REMARKS:

1. H AND B IS THE REQUIRED HORIZONTAL CLEARANCE ON THE OUTSIDE OF THE CURVE BASED ON MINIMUM CANT.
2. L AND C IS THE REQUIRED HORIZONTAL CLEARANCE ON THE INSIDE OF THE CURVE BASED ON MAXIMUM CANT.
3. INTERMEDIATE VALUES MAY BE INTERPOLATED BY THE ENGINEER IN CHARGE.
4. FOR WORKSHOP AREAS AND TEMPORARY WORK, CLEARANCES H AND L MAY BE REDUCED BY 300mm.
5. SEE ANNEXURE 1 SHEET 3 FOR PLATFORM CLEARANCES.
6. ALSO REFER TO REMARKS 4 TO 8 OF ANNEXURE 1 SHEET 2.

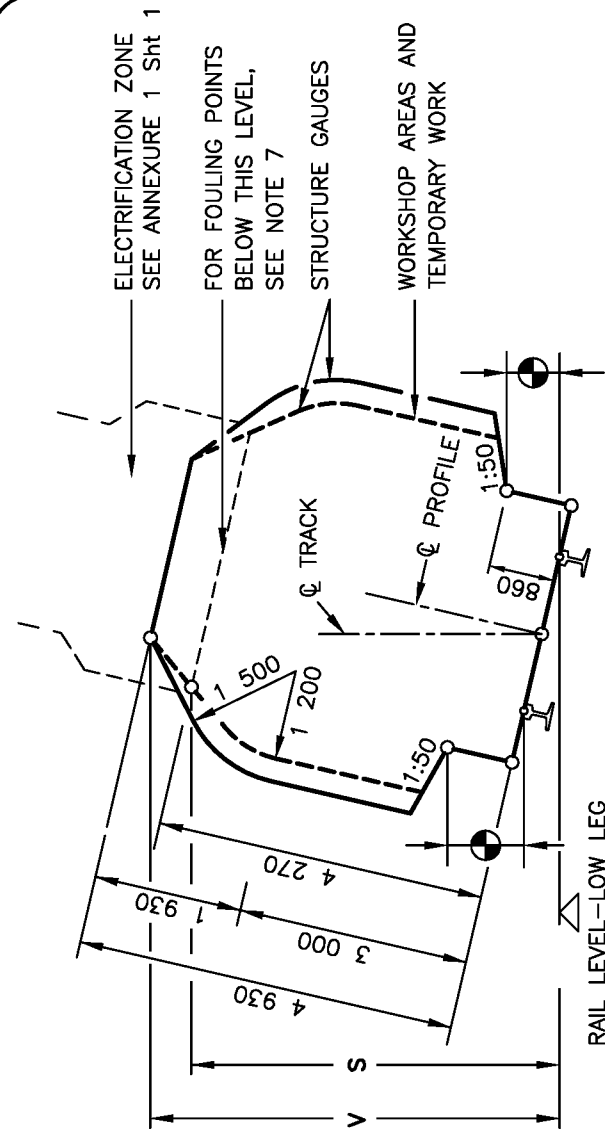

LOCATION	NOT ELECTRIFIED S (mm)	ELECTRIFIED (PRESENT OR FUTURE)	
		3kV & 25kV V (mm)	50kV V (mm)
RADIUS (mm)			
100	4 470	5 050	5 400
300	4 410	5 020	5 370
600	4 370	5 000	5 350
1 000	4 350	4 990	5 340
1 500	4 310	4 960	5 310
2 000	4 290	4 940	5 290
>3 000	4 270	4 930	5 280
* OVER OR NEAR POINTS AND CROSSING IF REQUIRED BY ELECTRICAL IRRESPECTIVE OF RADIUS			
ALL AREAS OTHER THAN THOSE INDICATED BY * BELOW			

REMARKS:

1. V IS THE REQUIRED VERTICAL CLEARANCE EXCEPT WHERE REDUCED CLEARANCE S APPLIES.
2. S IS THE MINIMUM VERTICAL CLEARANCE FOR STRUCTURES AND TEMPORARY WORK OVER NON-ELECTRIFIED LINES.
3. INTERMEDIATE VALUES MAY BE INTERPOLATED BY THE ENGINEER IN CHARGE.
4. FOR APPLICATION AT CURVES
 - 4.1 APPLY INCREASED CLEARANCES FOR CURVES TO POINTS 3m BEYOND THE ENDS OF THE CIRCULAR CURVE.
 - 4.2 REDUCE CLEARANCES AT A UNIFORM RATE OVER THE REMAINDER OF THE TRANSITION CURVE.
 - 4.3 FOR NON-TRANSITIONED CURVES REDUCE AT A UNIFORM RATE OVER A LENGTH OF 15m ALONG STRAIGHTS.
5. NEW STRUCTURES: SEE BRIDGE CODE.
6. TUNNELS: SEE DRAWING BE 82-35.
7. FOULING POINTS: SEE CLAUSE 8.1.
8. CLEARANCES ARE BASED ON 15m BOGIE CENTRES AND 21,2m VEHICLE BODY LENGTH.
9. SEE ANNEXURE 1 SHEET 3 FOR PLATFORM CLEARANCES.

PLATFORMS : TRACK GAUGE 1 065mm

PASSENGERS

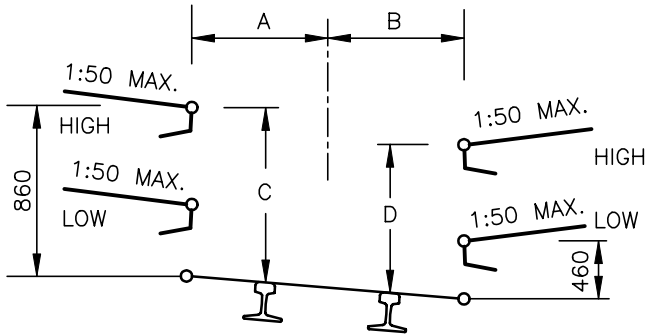

GOODS

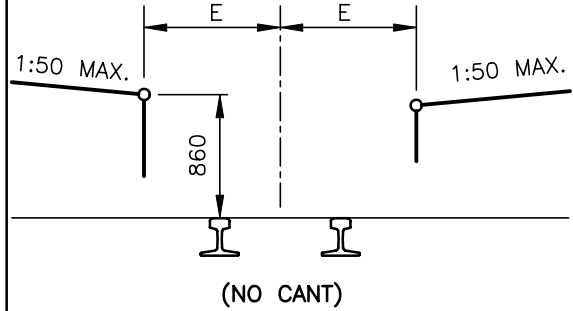

RADIUS (m)	A (mm)	B (mm)	C (mm)	D (mm)	E (mm)
90	1 690	1 820	890	810	1 840
100	1 650	1 790	890	810	1 810
120	1 610	1 740	890	810	1 760
140	1 580	1 700	890	810	1 720
170	1 550	1 660	890	810	1 690
200	1 530	1 630	890	820	1 670
250	1 520	1 600	890	820	1 640
300	1 520	1 580	890	830	1 620
350	1 520	1 560	880	830	1 600
400	1 520	1 550	880	840	1 590
500	1 520	1 540	880	850	1 580
600	1 520	1 530	870	850	1 570
800	1 520	1 520	860	860	1 560
1 200	1 520	1 520	860	860	1 550
2 000	1 520	1 520	860	860	1 540
3 000	1 520	1 520	860	860	1 530
STRAIGHT	1 520	1 520	860	860	1 520

REMARKS:

1. NO CANT TO BE APPLIED EXCEPT WHEN THE GOODS PLATFORM IS ON A RUNNING LINE.
2. INTERMEDIATE VALUES MAY BE INTERPOLATED BY THE ENGINEER IN CHARGE.
3.  8m TO MAIN STATION-BUILDINGS AND 3m TO ALL OTHER STRUCTURES.
4. TOLERANCES : SEE CLAUSE 8.0.10.

STRUCTURES ON PLATFORMS : 1 065mm AND 610mm TRACK GAUGE

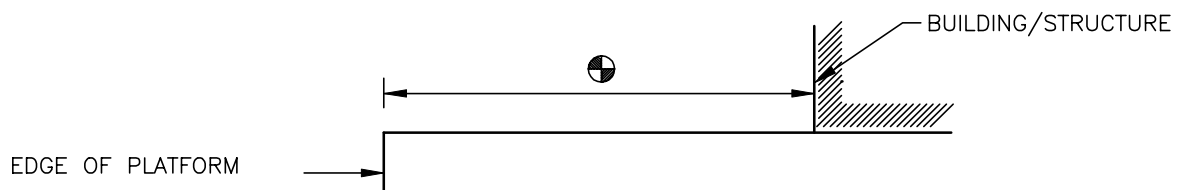

CLEARANCES : 610mm TRACK GAUGE

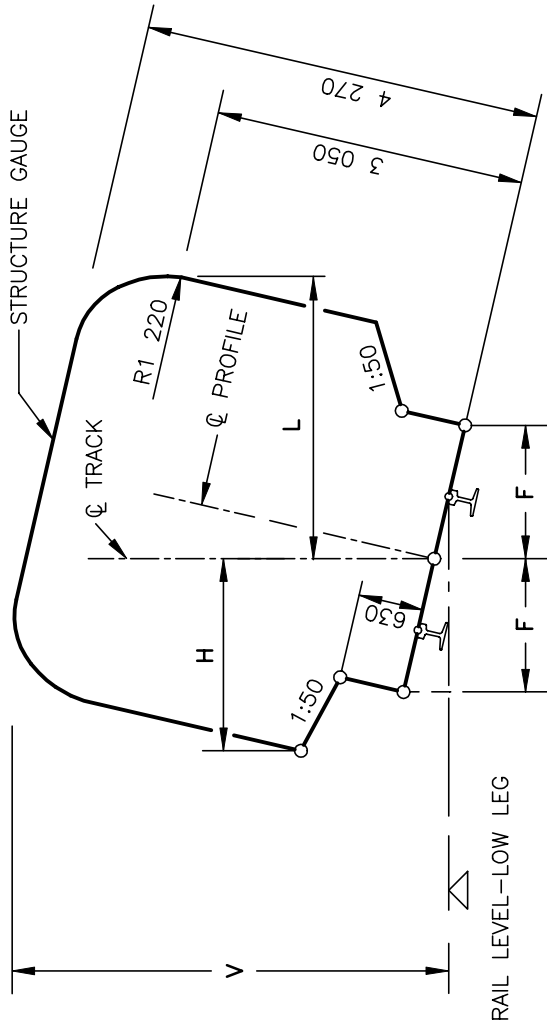

RADIUS (m)	F (mm)
50	1 550
60	1 510
80	1 460
100	1 430
120	1 410
140	1 390
170	1 380
200	1 370
250	1 360
300	1 350
600	1 330
1 000	1 320
>2 000	1 320
STRAIGHT	1 310

CLEARANCES

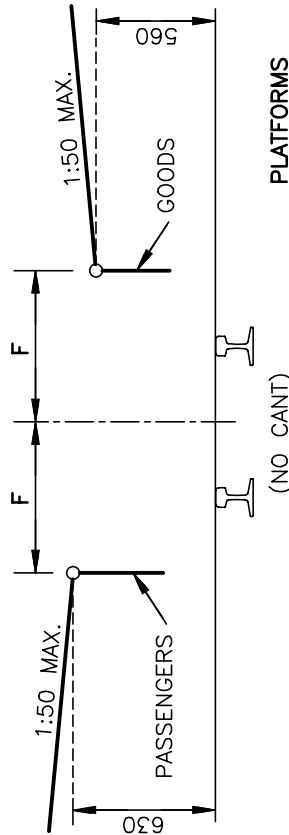

PLATFORMS

(NO CANT)

RADIUS (m)	WITH CANT		NO CANT		V (mm)
	H (mm)	L (mm)	H & L (mm)	V (mm)	
50	2 370	2 490	2 400	4 320	4 320
70	2 310	2 420	2 330	4 310	4 310
100	2 260	2 370	2 280	4 310	4 310
140	2 220	2 340	2 250	4 310	4 310
200	2 200	2 300	2 220	4 300	4 300
300	2 190	2 270	2 200	4 300	4 300
500	2 180	2 230	2 190	4 290	4 290
700	2 170	2 200	2 180	4 270	4 270
1 000	2 170	2 170	2 170	4 270	4 270
>2 000	2 160	2 160	2 160	4 270	4 270

REMARKS:

- H IS THE MINIMUM HORIZONTAL CLEARANCE ON THE OUTSIDE OF THE CURVE BASED ON MINIMUM CANT.
- L IS THE MINIMUM HORIZONTAL CLEARANCE ON THE INSIDE OF THE CURVE BASED ON MAXIMUM CANT.
- V IS THE MINIMUM VERTICAL CLEARANCE.
- FOR APPLICATION AT CURVES:
 - 1 APPLY INCREASED CLEARANCES FOR CURVES TO POINTS 2m BEYOND THE ENDS OF THE CIRCULAR CURVE.
 - 2 REDUCE CLEARANCES AT A UNIFORM RATE OVER THE REMAINDER OF THE TRANSITION CURVE.
 - 3 FOR NON-TRANSITIONED CURVES REDUCE AT A UNIFORM RATE OVER A LENGTH OF 18m ALONG STRAIGHTS.
- INTERMEDIATE VALUES MAY BE INTERPOLATED BY THE ENGINEER IN CHARGE.
- ALSO REFER TO REMARKS 5, 6 AND 7 OF ANNEXURE 1 SHEET 2.
- CLEARANCES ARE BASED ON 9 700mm BOGIE CENTRES AND 13 700mm VEHICLE BODY LENGTH.
- SEE ANNEXURE 1 SHEET 3 FOR STRUCTURES ON PLATFORMS.

T2.2-13: ANNEX G Compulsory Enterprise Questionnaire

The following particulars hereunder must be furnished.

In the case of a Joint Venture, separate enterprise questionnaires in respect of each partner/member must be completed and submitted.

Section 1: Name of enterprise: _____

Section 2: VAT registration number, if any: _____

Section 3: CIDB registration number, if any: _____

Section 4: CSD number: _____

Section 5: Particulars of sole proprietors and partners in partnerships

Name	Identity number	Personal income tax number

* Complete only if sole proprietor or partnership and attach separate page if more than 3 partners

Section 6: Particulars of companies and close corporations

Company registration number _____

Close corporation number _____

Tax reference number: _____

The SBD4 must be completed for each tender and be attached as a tender requirement.

The SBD 6 must be completed for each tender and be attached as a requirement.

The SBD8 must be completed for each tender and be attached as a requirement.

The SBD9 must be completed for each tender and be attached as a requirement.



The undersigned, who warrants that he / she is duly authorised to do so on behalf of the enterprise:

- i) authorizes the Employer to obtain a tax clearance certificate from the South African Revenue Services that my / our tax matters are in order;
- ii) confirms that the neither the name of the enterprise or the name of any partner, manager, director or other person, who wholly or partly exercises, or may exercise, control over the enterprise appears on the Register of Tender Defaulters established in terms of the Prevention and Combating of Corrupt Activities Act of 2004;
- iii) confirms that no partner, member, director or other person, who wholly or partly exercises, or may exercise, control over the enterprise appears, has within the last five years been convicted of fraud or corruption;
- iv) confirms that I / we are not associated, linked or involved with any other tendering entities submitting tender offers and have no other relationship with any of the tenderers or those responsible for compiling the scope of work that could cause or be interpreted as a conflict of interest; and
- v) confirms that the contents of this questionnaire are within my personal knowledge and are to the best of my belief both true and correct.

Signed	_____	Date	_____
Name	_____	Position	_____
Enterprise name	_____		

DECLARATION OF INTEREST

1. Any legal person, including persons employed by the state¹, or persons having a kinship with persons employed by the state, including a blood relationship, may make an offer or offers in terms of this invitation to bid (includes a price quotation, advertised competitive bid, limited bid or proposal). In view of possible allegations of favouritism, should the resulting bid, or part thereof, be awarded to persons employed by the state, or to persons connected with or related to them, it is required that the bidder or his/her authorised representative declare his/her position in relation to the evaluating/ adjudicating authority where-

- the bidder is employed by the state; and/or

- the legal person on whose behalf the bidding document is signed, has a relationship with persons/a person who are/is involved in the evaluation and or adjudication of the bid(s), or where it is known that such a relationship exists between the person or persons for or on whose behalf the declarant acts and persons who are involved with the evaluation and or adjudication of the bid.

¹"State" means –

- a) any national or provincial department, national or provincial public entity or constitutional institution within the meaning of the Public Finance Management Act, 1999 (Act No. 1 of 1999); any municipality or municipal entity;
- b) provincial legislature;
- c) national Assembly or the national Council of provinces; or
- d) Parliament.

SBD 4

2. In order to give effect to the above, the following questionnaire must be completed and submitted with the bid.

2.1 Full Name of bidder or his or her representative: _____

2.2 Identity Number: _____

2.3 Position occupied in the Company (director, trustee, shareholder²):

2.4 Company Registration Number: _____

2.5 Tax Reference Number: _____

2.6 VAT Registration Number: _____

2.6.1 The names of all directors / trustees / shareholders / members, their individual identity numbers, tax reference numbers and, if applicable, employee / personnel numbers must be indicated in paragraph 3 below.

2.7 Are you or any person connected with the bidder presently employed by the state?

YES / NO

2.7.1 If so, furnish the following particulars:

- Name of person / director / trustee / shareholder/ member:

- Name of state institution at which you or the person connected to the bidder is employed:

- Position occupied in the state institution:

Any other particulars:

² "Shareholder" means a person who owns shares in the company and is actively involved in the management of the enterprise or business and exercises control over the enterprise.

SBD 4

2.7.2 If you are presently employed by the state, did you obtain the appropriate authority to undertake remunerative work outside employment in the public sector?

YES / NO

2.7.3 If yes, did you attached proof of such authority to the bid document?

YES / NO

Note: Failure to submit proof of such authority, where applicable, may result in the disqualification of the bid.

2.7.3.1 If no, furnish reasons for non-submission of such proof:

2.8 Did you or your spouse, or any of the company's directors / trustees / shareholders / members or their spouses conduct business with the state in the previous twelve months?

YES / NO

2.8.1 If so, furnish particulars:

2.9 Do you, or any person connected with the bidder, have any relationship (family, friend, other) with a person employed by the state and who may be involved with the evaluation and or adjudication of this bid?

YES / NO

2.8.2 If so, furnish particulars.

SBD 4

2.9 Are you, or any person connected with the bidder, aware of any relationship (family, friend, other) between any other bidder and any person employed by the state who may be involved with the evaluation and or adjudication of this bid?

YES/NO

2.9.1 If so, furnish particulars.

2.10 Do you or any of the directors / trustees / shareholders / members of the company have any interest in any other related companies whether or not they are bidding for this contract?

YES/NO

2.10.1 If so, furnish particulars:

SBD 4

3 Full details of directors / trustees / members / shareholders.

Full Name	Identity Number	Personal Tax Reference Number	State Employee Number / Persal Number

SBD 4

4 DECLARATION

I, THE UNDERSIGNED (NAME) _____ CERTIFY
THAT THE INFORMATION FURNISHED IN PARAGRAPHS 2 and 3 ABOVE IS CORRECT.

I ACCEPT THAT THE STATE MAY REJECT THE BID OR ACT AGAINST ME IN TERMS OF
PARAGRAPH 23 OF THE GENERAL CONDITIONS OF CONTRACT SHOULD THIS
DECLARATION PROVE TO BE FALSE.

Signature

Date

Position

Name of bidder

SBD 6.1

PREFERENCE POINTS CLAIM FORM IN TERMS OF THE PREFERENTIAL PROCUREMENT REGULATIONS 2017

This preference form must form part of all bids invited. It contains general information and serves as a claim for preference points for Broad-Based Black Economic Empowerment [**B-BBEE**] Status Level of Contribution.

Transnet will award preference points to companies who provide valid proof of their B-BBEE status using either the latest version of the generic Codes of Good Practice or Sector Specific Codes (if applicable).

NB: BEFORE COMPLETING THIS FORM, BIDDERS MUST STUDY THE GENERAL CONDITIONS, DEFINITIONS AND DIRECTIVES APPLICABLE IN RESPECT OF B-BBEE, AS PRESCRIBED IN THE PREFERENTIAL PROCUREMENT REGULATIONS, 2017.

1. GENERAL CONDITIONS

1.1 The following preference point systems are applicable to all bids:

- the 80/20 system for requirements with a Rand value of up to R50 000 000 (all applicable taxes included); and
- the 90/10 system for requirements with a Rand value above R50 000 000 (all applicable taxes included).

1.2 **Eastern Region** value of this bid is estimated to exceed R50 000 000 (all applicable taxes included) and therefore the **10** preference point system shall be applicable.

1.3 **Western and Central Region** value of this bid is estimated to not exceed R50 000 000 (all applicable taxes included) and therefore the **20** preference point system shall be applicable.

1.4 Despite the stipulated preference point system, Transnet shall use the lowest acceptable bid to determine the applicable preference point system in a situation where all received acceptable bids are received outside the stated preference point system.

1.5 Preference points for this bid shall be awarded for:

- (a) Price; and
- (b) B-BBEE Status Level of Contribution.

1.6 The maximum points for this bid are allocated as follows:

	POINTS
PRICE	80
B-BBEE STATUS LEVEL OF CONTRIBUTION	20
Total points for Price and B-BBEE must not exceed	100

1.7 Failure on the part of a bidder to submit proof of B-BBEE status level of contributor together with the bid will be interpreted to mean that preference points for B-BBEE status level of contribution are not claimed.

1.8 The purchaser reserves the right to require of a bidder, either before a bid is adjudicated or at any time subsequently, to substantiate any claim in regard to preferences, in any manner required by the purchaser.

2. DEFINITIONS

- (a) **"all applicable taxes"** includes value-added tax, pay as you earn, income tax, unemployment insurance fund contributions and skills development levies;
- (b) **"B-BBEE"** means broad-based black economic empowerment as defined in section 1 of the Broad-Based Black Economic Empowerment Act;
- (c) **"B-BBEE status level of contributor"** means the B-BBEE status received by a measured entity based on its overall performance using the relevant scorecard contained in the Codes of Good Practice on Black Economic Empowerment, issued in terms of section 9(1) of the Broad-Based Black Economic Empowerment Act;
- (d) **"bid"** means a written offer in a prescribed or stipulated form in response to an invitation by an organ of state for the supply/provision of services, works or goods, through price quotations, advertised competitive bidding processes or proposals;
- (e) **"Broad-Based Black Economic Empowerment Act"** means the Broad-Based Black Economic Empowerment Act, 2003 (Act No. 53 of 2003);
- (f) **"EME"** means an Exempted Micro Enterprise as defines by Codes of Good Practice under section 9 (1) of the Broad-Based Black Economic Empowerment Act, 2003 (Act No. 53 of 2003);
- (g) **"functionality"** means the ability of a bidder to provide goods or services in accordance with specification as set out in the bid documents
- (h) **"Price"** includes all applicable taxes less all unconditional discounts.
- (i) **"Proof of B-BBEE Status Level of Contributor"**
 - i) the B-BBBEE status level certificate issued by an authorised body or person;
 - ii) a sworn affidavit as prescribed by the B-BBEE Codes of Good Practice; or
 - iii) any other requirement prescribed in terms of the B-BBEE Act.
- (j) **"QSE"** means a Qualifying Small EEnterprise as defines by Codes of Good Practice under section 9 (1) of the Broad-Based Black Economic Empowerment Act, 2003 (

Act No. 53 of 2003);

(k) **“rand value”** means the total estimated value of a contract in South African currency, calculated at the time of bid invitations, and includes all applicable taxes and excise duties.

3. POINTS AWARDED FOR PRICE

3.1 THE 80/20 OR 90/10 PREFERENCE POINT SYSTEMS

A maximum of 80 points is allocated for price on the following basis:

80

$$PS = 80 \left(1 + \frac{Pt - P_{max}}{P_{max}} \right)$$

Where:

Ps = Points scored for the price of Bid under consideration
Pt = Price of Bid under consideration
Pmax = Price of highest acceptable Bid

POINTS AWARDED FOR B-BBEE STATUS LEVEL OF CONTRIBUTION

3.2 In terms of Regulation 6 (2) of the Preferential Procurement Regulations, preference points must be awarded to a bidder for attaining the B-BBEE status level of contribution in accordance with the table below:

B-BBEE Status Level of Contributor	Number of points (80/20 system)
1	20
2	18
3	14
4	12
5	8
6	6
7	4
8	2
Non-compliant contributor	0

3.3 The table below indicates the required proof of B-BBEE status depending on the category of enterprises:

Enterprise	B-BBEE Certificate & Sworn Affidavit
Large	Certificate issued by SANAS accredited verification agency
QSE	Certificate issued by SANAS accredited verification agency Sworn Affidavit signed by the authorised QSE representative and attested by a Commissioner of Oaths confirming annual turnover and black ownership (only black-owned QSEs - 51% to 100% Black owned)

	[Sworn affidavits must substantially comply with the format that can be obtained on the DTI's website at www.dti.gov.za/economic_empowerment/bee_codes.jsp .]
EME³	Sworn Affidavit signed by the authorised EME representative and attested by a Commissioner of Oaths confirming annual turnover and black ownership Certificate issued by CIPC (formerly CIPRO) confirming annual turnover and black ownership Certificate issued by SANAS accredited verification agency only if the EME is being measured on the QSE scorecard

- 3.4 A trust, consortium or joint venture (including unincorporated consortia and joint ventures) must submit a consolidated B-BBEE Status Level verification certificate for every separate bid.
- 3.5 Tertiary Institutions and Public Entities will be required to submit their B-BBEE status level certificates in terms of the specialized scorecard contained in the B-BBEE Codes of Good Practice.
- 3.6 A person will not be awarded points for B-BBEE status level if it is indicated in the bid documents that such a bidder intends sub-contracting more than 25% of the value of the contract to any other enterprise that does not qualify for at least the points that such a bidder qualifies for, unless the intended sub-contractor is an EME that has the capability and ability to execute the sub-contract.
- 3.7 A person awarded a contract may not sub-contract more than 25% of the value of the contract to any other enterprise that does not have an equal or higher B-BBEE status level than the person concerned, unless the contract is sub-contracted to an EME that has the capability and ability to execute the sub-contract.
- 3.8 Bidders are to note that the rules pertaining to B-BBEE verification and other B-BBEE requirements may be changed from time to time by regulatory bodies such as National Treasury or the DTI. It is the Bidder's responsibility to ensure that his/her bid complies fully with all B-BBEE requirements at the time of the submission of the bid.

4. BID DECLARATION

- 4.1 Bidders who claim points in respect of B-BBEE Status Level of Contribution must complete the following:

5. B-BBEE STATUS LEVEL OF CONTRIBUTION CLAIMED IN TERMS OF PARAGRAPHS 1.4 AND 6.1

- 5.1 B-BBEE Status Level of Contribution: . =(maximum of 10 or 20 points)

³ In terms of the Implementation Guide: Preferential Procurement Regulations, 2017, Version 2, paragraph 11.11 provides that in the Transport Sector, EMEs can provide a letter from accounting officer or get verified and be issued with a B-BBEE certificate by SANAS accredited professional or agency as the Transport Sector Code has not been aligned to the generic Codes. EMEs in the Transport Sector are not allowed to provide a sworn affidavit as the generic codes are not applicable to them.

(Points claimed in respect of paragraph 6.1 must be in accordance with the table reflected in paragraph 4.1 and must be substantiated by relevant proof of B-BBEE status level of contributor.

6. SUB-CONTRACTING

6.1 Will any portion of the contract be sub-contracted?

(Tick applicable box)

YES	<input type="checkbox"/>	NO	<input type="checkbox"/>
-----	--------------------------	----	--------------------------

6.1.1 If yes, indicate:

- i) What percentage of the contract will be subcontracted.....%
- ii) The name of the sub-contractor.....
- iii) The B-BBEE status level of the sub-contractor.....
- iv) Whether the sub-contractor is an EME or QSE.

(Tick applicable box)

YES	<input type="checkbox"/>	NO	<input type="checkbox"/>
-----	--------------------------	----	--------------------------

v) Specify, by ticking the appropriate box, if subcontracting with an enterprise in terms of Preferential Procurement Regulations,2017:

Designated Group: An EME or QSE which is at last 51% owned by:	EME <input checked="" type="checkbox"/>	QSE <input checked="" type="checkbox"/>
Black people	<input type="checkbox"/>	<input type="checkbox"/>
Black people who are youth	<input type="checkbox"/>	<input type="checkbox"/>
Black people who are women	<input type="checkbox"/>	<input type="checkbox"/>
Black people with disabilities	<input type="checkbox"/>	<input type="checkbox"/>
Black people living in rural or underdeveloped areas or townships	<input type="checkbox"/>	<input type="checkbox"/>
Cooperative owned by black people	<input type="checkbox"/>	<input type="checkbox"/>
Black people who are military veterans	<input type="checkbox"/>	<input type="checkbox"/>
OR		
Any EME	<input type="checkbox"/>	<input type="checkbox"/>
Any QSE	<input type="checkbox"/>	<input type="checkbox"/>

7. DECLARATION WITH REGARD TO COMPANY/FIRM

7.1 Name of company/firm:.....

7.2 VAT registration number:.....

7.3 Company registration number:.....

7.4 TYPE OF COMPANY/ FIRM

- Partnership/Joint Venture / Consortium
- One person business/sole propriety
- Close corporation



- Company
 - (Pty) Limited
- [TICK APPLICABLE BOX]

7.5 DESCRIBE PRINCIPAL BUSINESS ACTIVITIES

.....
.....
.....

7.6 COMPANY CLASSIFICATION

- Manufacturer
 - Supplier
 - Professional Supplier/Service provider
 - Other Suppliers/Service providers, e.g. transporter, etc.
- [TICK APPLICABLE BOX]

7.7 Total number of years the company/firm has been in business:.....

7.8 I/we, the undersigned, who is / are duly authorised to do so on behalf of the company/firm, certify that the points claimed, based on the B-BBE status level of contribution indicated in paragraphs 1.4 and 6.1 of the foregoing certificate, qualifies the company/ firm for the preference(s) shown and I / we acknowledge that:

- i) The information furnished is true and correct;
- ii) The preference points claimed are in accordance with the General Conditions as indicated in paragraph 1 of this form;
- iii) In the event of a contract being awarded as a result of points claimed as shown in paragraph 1.4 and 6.1, the contractor may be required to furnish documentary proof to the satisfaction of the purchaser that the claims are correct;
- iv) If a bidder submitted false information regarding its B-BBEE status level of contributor, local production and content, or any other matter required in terms of the Preferential Procurement Regulations, 2017 which will affect or has affected the evaluation of a bid, or where a bidder has failed to declare any subcontracting arrangements or any of the conditions of contract have not been fulfilled, the purchaser may, in addition to any other remedy it may have
 - (a) disqualify the person from the bidding process;
 - (b) recover costs, losses or damages it has incurred or suffered as a result of that person's conduct;
 - (c) cancel the contract and claim any damages which it has suffered as a result of having to make less favourable arrangements due to such cancellation;
 - (d) if the successful bidder subcontracted a portion of the bid to another person without disclosing it, Transnet reserves the right to penalise the bidder up to 10 percent of the value of the contract;
 - (e) recommend that the bidder or contractor, its shareholders and directors, or only the shareholders and directors who acted on a



fraudulent basis, be restricted by the National Treasury from obtaining business from any organ of state for a period not exceeding 10 years, after the audi alteram partem (hear the other side) rule has been applied; and

- (f) forward the matter for criminal prosecution.

<p>WITNESSES</p> <p>1.</p> <p>2.</p>
--

<p>.....</p> <p>SIGNATURE(S) OF BIDDERS(S)</p> <p>DATE:</p>

DECLARATION OF BIDDER’S PAST SUPPLY CHAIN MANAGEMENT PRACTICES

1. This Standard Bidding Document must form part of all bids invited.
2. It serves as a declaration to be used by institutions in ensuring that when goods and services are being procured, all reasonable steps are taken to combat the abuse of the supply chain management system.
3. The bid of any bidder may be disregarded if that bidder, or any of its directors have-
 - a. abused the institution’s supply chain management system;
 - b. committed fraud or any other improper conduct in relation to such system; or
 - c. failed to perform on any previous contract.
- 4. In order to give effect to the above, the following questionnaire must be completed and submitted with the bid.**

Item	Question	Yes	No
4.1	Is the bidder or any of its directors listed on the National Treasury’s database as companies or persons prohibited from doing business with the public sector? (Companies or persons who are listed on this database were informed in writing of this restriction by the National Treasury after the <i>audi alteram partem</i> rule was applied).	Yes <input type="checkbox"/>	No <input type="checkbox"/>
4.1.1	If so, furnish particulars:		
4.2	Is the bidder or any of its directors listed on the Register for Tender Defaulters in terms of section 29 of the Prevention and Combating of Corrupt Activities Act (No 12 of 2004)? To access this Register enter the National Treasury’s website, www.treasury.gov.za, click on the icon “Register for Tender Defaulters” or submit your written request for a hard copy of the Register to facsimile number (012) 3265445.	Yes <input type="checkbox"/>	No <input type="checkbox"/>
4.2.1	If so, furnish particulars:		

4.3	Was the bidder or any of its directors convicted by a court of law (including a court outside of the Republic of South Africa) for fraud or corruption during the past five years?	Yes <input type="checkbox"/>	No <input type="checkbox"/>
4.3.1	If so, furnish particulars:		
4.4	Was any contract between the bidder and any organ of state terminated during the past five years on account of failure to perform on or comply with the contract?	Yes <input type="checkbox"/>	No <input type="checkbox"/>
4.4.1	If so, furnish particulars:		



SBD 8

CERTIFICATION

I, THE UNDERSIGNED (FULL NAME)..... CERTIFY THAT THE INFORMATION FURNISHED ON THIS DECLARATION FORM IS TRUE AND CORRECT.

I ACCEPT THAT, IN ADDITION TO CANCELLATION OF A CONTRACT, ACTION MAY BE TAKEN AGAINST ME SHOULD THIS DECLARATION PROVE TO BE FALSE.

Signature

Date

Position

Name of Tenderer

SBD 9

CERTIFICATE OF INDEPENDENT BID DETERMINATION

1. This Standard Bidding Document (SBD) must form part of all bids/quotes⁴ invited.
2. Section 4 (1) (b) (iii) of the Competition Act No. 89 of 1998, as amended, prohibits an agreement between, or concerted practice by, firms, or a decision by an association of firms, if it is between parties in a horizontal relationship and if it involves collusive bidding (or bid rigging).⁵ Collusive bidding is a *pe se* prohibition meaning that it cannot be justified under any grounds.
3. Treasury Regulation 16A9 prescribes that accounting officers and accounting authorities must take all reasonable steps to prevent abuse of the supply chain management system and authorizes accounting officers and accounting authorities to:
 - (a) disregard the bid of any bidder if that bidder, or any of its directors have abused the institution's supply chain management system and or committed fraud or any other improper conduct in relation to such system.
 - (b) cancel a contract awarded to a supplier of goods and services if the supplier committed any corrupt or fraudulent act during the bidding process or the execution of that contract.
4. This SBD serves as a certificate of declaration that would be used by institutions to ensure that, when bids are considered, reasonable steps are taken to prevent any form of bid-rigging.
5. In order to give effect to the above, the attached Certificate of Bid Determination (SBD 9) must be completed and submitted with the bid:

⁴ Includes price quotations, advertised competitive bids, limited bids and proposals.

⁵ Bid rigging (or collusive bidding) occurs when businesses, that would otherwise be expected to compete, secretly conspire to raise prices or lower the quality of goods and / or services for purchasers who wish to acquire goods and / or services through a bidding process. Bid rigging is, therefore, an agreement between competitors not to compete.

SBD 9

CERTIFICATE OF INDEPENDENT QUOTATION/PROPOSAL DETERMINATION

I, the undersigned, in submitting the accompanying quote:

(Quote Number and Description)

in response to the invitation for the quote made by:

(Name of Institution)

do hereby make the following statements that I certify to be true and complete in every respect:

I certify, on behalf of: _____ that:
(Name of Bidder)

1. I have read and I understand the contents of this Certificate;
2. I understand that the accompanying bid will be disqualified if this Certificate is found not to be true and complete in every respect;
3. I am authorized by the bidder to sign this Certificate, and to submit the accompanying bid, on behalf of the bidder;
4. Each person whose signature appears on the accompanying bid has been authorized by the bidder to determine the terms of, and to sign the bid, on behalf of the bidder;
5. For the purposes of this Certificate and the accompanying bid, I understand that the word "competitor" shall include any individual or organization, other than the bidder, whether or not affiliated with the bidder, who:
 - (a) has been requested to submit a bid in response to this bid invitation;
 - (b) could potentially submit a bid in response to this bid invitation, based on their qualifications, abilities or experience; and
 - (c) provides the same goods and services as the bidder and/or is in the same line of business as the bidder

SBD 9

6. The bidder has arrived at the accompanying bid independently from, and without consultation, communication, agreement or arrangement with any competitor. However communication between partners in a joint venture or consortium⁶ will not be construed as collusive bidding.
7. In particular, without limiting the generality of paragraphs 6 above, there has been no consultation, communication, agreement or arrangement with any competitor regarding:
 - (a) prices;
 - (b) geographical area where product or service will be rendered (market allocation)
 - (c) methods, factors or formulas used to calculate prices;
 - (d) the intention or decision to submit or not to submit, a bid;
 - (e) the submission of a bid which does not meet the specifications and conditions of the bid; or
 - (f) bidding with the intention not to win the bid.
8. In addition, there have been no consultations, communications, agreements or arrangements with any competitor regarding the quality, quantity, specifications and conditions or delivery particulars of the products or services to which this bid invitation relates.
9. The terms of the accompanying bid have not been, and will not be, disclosed by the bidder, directly or indirectly, to any competitor, prior to the date and time of the official bid opening or of the awarding of the contract.

⁶ Joint venture or Consortium means an association of persons for the purpose of combining their expertise, property, capital, efforts, skill and knowledge in an activity for the execution of a contract.



10. I am aware that, in addition and without prejudice to any other remedy provided to combat any restrictive practices related to bids and contracts, bids that are suspicious will be reported to the Competition Commission for investigation and possible imposition of administrative penalties in terms of section 59 of the Competition Act No 89 of 1998 and or may be reported to the National Prosecuting Authority (NPA) for criminal investigation and or may be restricted from conducting business with the public sector for a period not exceeding ten (10) years in terms of the Prevention and Combating of Corrupt Activities Act No 12 of 2004 or any other applicable legislation.

Signature

Date

Position

Name of bidder

T2.2-14 : Supplier Code of Conduct

Transnet SOC Limited aims to achieve the best value for money when buying or selling goods and obtaining services. This however must be done in an open and fair manner that supports and drives a competitive economy. Underpinning our process are several acts and policies that any supplier dealing with Transnet must understand and support. These are:

- The Transnet Procurement Policy – A guide for Tenderers.
- Section 217 of the Constitution - the five pillars of Public PSCM (Procurement and Supply Chain Management): fair, equitable, transparent, competitive and cost effective;
- The Public Finance Management Act (PFMA);
- The Broad Based Black Economic Empowerment Act (BBBEE)
- The Prevention and Combating of Corrupt Activities Act (PRECCA); and
- The Construction Industry Development Board Act (CIDB Act).

This code of conduct has been included in this contract to formally appraise Transnet Suppliers of Transnet's expectations regarding behaviour and conduct of its Suppliers.

Prohibition of Bribes, Kickbacks, Unlawful Payments, and Other Corrupt Practices

Transnet is in the process of transforming itself into a self-sustaining State Owned Enterprise, actively competing in the logistics industry. Our aim is to become a world class, profitable, logistics organisation. As such, our transformation is focused on adopting a performance culture and to adopt behaviours that will enable this transformation.

1. Transnet SOC Limited will not participate in corrupt practices. Therefore, it expects its suppliers to act in a similar manner.

- Transnet and its employees will follow the laws of this country and keep accurate business records that reflect actual transactions with, and payments to, our suppliers.
- Employees must not accept or request money or anything of value, directly or indirectly, from suppliers.
- Employees may not receive anything that is calculated to:
 - Illegally influence their judgement or conduct or to ensure the desired outcome of a sourcing activity;

- Win or retain business or to influence any act or decision of any person involved in sourcing decisions; or
- Gain an improper advantage.
- There may be times when a supplier is confronted with fraudulent or corrupt behaviour of Transnet employees. We expect our Suppliers to use our “Tip-offs Anonymous” Hot line to report these acts. (0800 003 056).

2. *Transnet SOC Limited is firmly committed to the ideas of free and competitive enterprise.*

- Suppliers are expected to comply with all applicable laws and regulations regarding fair competition and antitrust practices.
- Transnet does not engage with non-value adding agents or representatives solely for the purpose of increasing BBBEE spend (fronting).

3. *Transnet’s relationship with suppliers requires us to clearly define requirements, to exchange information and share mutual benefits.*

- Generally, suppliers have their own business standards and regulations. Although Transnet cannot control the actions of our suppliers, we will not tolerate any illegal activities. These include, but are not limited to:
 - Misrepresentation of their product (origin of manufacture, specifications, intellectual property rights, etc);
 - Collusion;
 - Failure to disclose accurate information required during the sourcing activity (ownership, financial situation, BBBEE status, etc.);
 - Corrupt activities listed above; and
 - Harassment, intimidation or other aggressive actions towards Transnet employees.
- Suppliers must be evaluated and approved before any materials, components, products or services are purchased from them. Rigorous due diligence is conducted and the supplier is expected to participate in an honest and straight forward manner.
- Suppliers must record and report facts accurately, honestly and objectively. Financial records must be accurate in all material respects.



Conflicts of Interest

A conflict of interest arises when personal interests or activities influence (or appear to influence) the ability to act in the best interests of Transnet SOC Limited.

- Doing business with family members.
- Having a financial interest in another company in our industry

Where possible, contracts will be negotiated to include the above in the terms of such contracts. To the extent such terms are not included in contractual obligations and any of the above code is breached, then Transnet reserves its right to review doing business with these suppliers.

I, _____ of _____
(insert name of Director or as per Authority Resolution from Board of Directors) *(insert name of Company)*

hereby acknowledge having read, understood and agree to the terms and conditions set out in the "Transnet Supplier Code of Conduct."

Signed this on day _____ at

Signature

T2.2-15 Service Provider Integrity Pact

Important Note: All potential tenderers must read this document and certify in the RFP Declaration Form that that have acquainted themselves with, and agree with the content.

The contract with the successful tenderer will automatically incorporate this Integrity Pact and shall be deemed as part of the final concluded contract.

INTEGRITY PACT

Between

TRANSNET SOC LTD

Registration Number: 1990/000900/30

("Transnet")

and

The Contractor (hereinafter referred to as the "Tenderer/Service Providers/Contractor")

PREAMBLE

Transnet values full compliance with all relevant laws and regulations, ethical standards and the principles of economical use of resources, fairness and transparency in its relations with its Tenderers / Service Providers/Contractors.

In order to achieve these goals, Transnet and the Tenderer / Service Provider hereby enter into this agreement hereinafter referred to as the "Integrity Pact" which will form part of the Tenderer's / Service Provider's / Contractor's application for registration with Transnet as a vendor.

The general purpose of this Integrity Pact is to agree on avoiding all forms of dishonesty, fraud and corruption by following a system that is fair, transparent and free from any undue influence prior to, during and subsequent to the currency of any procurement and / or reverse logistics event and any further contract to be entered into between the Parties, relating to such event.

All Tenderers / Service Providers / Contractor's will be required to sign and comply with undertakings contained in this Integrity Pact, should they want to be registered as a Transnet vendor.

1 OBJECTIVES

- 1.1 Transnet and the Tenderer / Service Provider / Contractor agree to enter into this Integrity Pact, to avoid all forms of dishonesty, fraud and corruption including practices that are anti-competitive in nature, negotiations made in bad faith and under-pricing by following a system that is fair, transparent and free from any influence / unprejudiced dealings prior to, during and subsequent to the currency of the contract to be entered into with a view to:
- a) Enable Transnet to obtain the desired contract at a reasonable and competitive price in conformity to the defined specifications of the works, goods and services; and
 - b) Enable Tenderers / Service Providers / Contractors to abstain from bribing or participating in any corrupt practice in order to secure the contract.

2 COMMITMENTS OF TRANSNET

Transnet commits to take all measures necessary to prevent dishonesty, fraud and corruption and to observe the following principles:

- 2.1 Transnet hereby undertakes that no employee of Transnet connected directly or indirectly with the sourcing event and ensuing contract, will demand, take a promise for or accept directly or through intermediaries any bribe, consideration, gift, reward, favour or any material or immaterial benefit or any other advantage from the Tenderer, either for themselves or for any person, organisation or third party related to the contract in exchange for an advantage in the tendering

process, Tender evaluation, contracting or implementation process related to any contract.

- 2.2 Transnet will, during the registration and tendering process treat all Tenderers / Service Providers with equity, transparency and fairness. Transnet will in particular, before and during the registration process, provide to all Tenderers / Service Providers the same information and will not provide to any Tenderers / Service Providers / Contractors confidential / additional information through which the Tenderers / Service Providers / Contractors could obtain an advantage in relation to any tendering process.
- 2.3 Transnet further confirms that its employees will not favour any prospective Tenderer in any form that could afford an undue advantage to a particular Tenderer during the tendering stage, and will further treat all Tenderers / Service Providers / Contractors participating in the tendering process.
- 2.4 Transnet will exclude from the tender process such employees who have any personal interest in the Tenderers / Service Providers / Contractors participating in the tendering process.

3 OBLIGATIONS OF THE TENDERER / SERVICE PROVIDER

- 3.1 The Tenderer / Service Provider / Contractor commits itself to take all measures necessary to prevent corrupt practices, unfair means and illegal activities during any stage of its Tender or during any ensuing contract stage in order to secure the contract or in furtherance to secure it and in particular the Tenderer / Service Provider / Contractor commits to the following:
 - a) The Tenderer / Service Provider / Contractor will not, directly or through any other person or firm, offer, promise or give to Transnet or to any of Transnet's employees involved in the tendering process or to any third person any material or other benefit or payment, in order to obtain in exchange an advantage during the tendering process; and
 - b) The Tenderer / Service Provider / Contractor will not offer, directly or through intermediaries, any bribe, gift, consideration, reward, favour, any material or immaterial benefit or other advantage, commission, fees, brokerage or inducement to any employee of Transnet, connected directly or indirectly with the tendering process, or to any person, organisation or third party related to the contract in exchange for any advantage in the tendering, evaluation, contracting and implementation of the contract.
- 3.2 The acceptance and giving of gifts may be permitted provided that:
 - a) the gift does not exceed R1 000 (one thousand Rand) in retail value;
 - b) many low retail value gifts do not exceed R 1 000 within a 12 month period;

- c) hospitality packages do not exceed R5 000 in value or many low value hospitality packages do not cumulatively exceed R5 000;
 - d) a Tenderer / Service Provider does not give a Transnet employee more than 2 (two) gifts within a 12 (twelve) month period, irrespective of value;
 - e) a Tenderer / Service Provider does not accept more than 1 (one) gift in excess of R750 (seven hundred and fifty Rand) from a Transnet employee within a 12 (twelve) month period, irrespective of value;
 - f) a Tenderer / Service Provider may under no circumstances, accept from or give to, a Transnet employee any gift, business courtesy, including an invitation to a business meal and /or drinks, or hospitality package, irrespective of value, during any Tender evaluation process, including a period of 12 (twelve) months after such tender has been awarded, as it may be perceived as undue and improper influence on the evaluation process or reward for the contract that has been awarded; and
 - g) a Tenderer / Service Provider may not offer gifts, goods or services to a Transnet employee at artificially low prices, which are not available to the public at those prices.
- 3.3 The Tenderer / Service Provider / Contractor will not collude with other parties interested in the contract to preclude a competitive Tender price, impair the transparency, fairness and progress of the tendering process, Tender evaluation, contracting and implementation of the contract. The Tenderer / Service Provider further commits itself to delivering against all agreed upon conditions as stipulated within the contract.
- 3.4 The Tenderer / Service Provider / Contractor will not enter into any illegal or dishonest agreement or understanding, whether formal or informal with other Tenderers / Service Providers / Contractors. This applies in particular to certifications, submissions or non-submission of documents or actions that are restrictive or to introduce cartels into the tendering process.
- 3.5 The Tenderer / Service Provider / Contractor will not commit any criminal offence under the relevant anti-corruption laws of South Africa or any other country. Furthermore, the Tenderer /Service Provider will not use for illegitimate purposes or for restrictive purposes or personal gain, or pass on to others, any information provided by Transnet as part of the business relationship, regarding plans, technical proposals and business details, including information contained or transmitted electronically.
- 3.6 A Tenderer / Service Provider / Contractor of foreign origin shall disclose the name and address of its agents or representatives in South Africa, if any, involved directly or indirectly in the registration or tendering process. Similarly, the Tenderer / Service Provider / Contractor of South African nationality shall furnish

the name and address of the foreign principals, if any, involved directly or indirectly in the registration or tendering process.

- 3.7 The Tenderer / Service Provider / Contractor will not misrepresent facts or furnish false or forged documents or information in order to influence the tendering process to the advantage of the Tenderer / Service Provider or detriment of Transnet or other competitors.
- 3.8 The Tenderer / Service Provider / Contractor shall furnish Transnet with a copy of its code of conduct, which code of conduct shall reject the use of bribes and other dishonest and unethical conduct, as well as compliance programme for the implementation of the code of conduct.
- 3.9 The Tenderer / Service Provider / Contractor will not instigate third persons to commit offences outlined above or be an accessory to such offences.

4 INDEPENDENT TENDERING

- 4.1 For the purposes of that Certificate in relation to any submitted Tender, the Tenderer declares to fully understand that the word "competitor" shall include any individual or organisation, other than the Tenderer, whether or not affiliated with the Tenderer, who:
 - a) has been requested to submit a Tender in response to this Tender invitation;
 - b) could potentially submit a Tender in response to this Tender invitation, based on their qualifications, abilities or experience; and
 - c) provides the same Goods and Services as the Tenderer and/or is in the same line of business as the Tenderer.
- 4.2 The Tenderer has arrived at his submitted Tender independently from, and without consultation, communication, agreement or arrangement with any competitor. However communication between partners in a joint venture or consortium will not be construed as collusive tendering.
- 4.3 In particular, without limiting the generality of paragraph 5 above, there has been no consultation, communication, agreement or arrangement with any competitor regarding:
 - a) prices;
 - b) geographical area where Goods or Services will be rendered [market allocation];
 - c) methods, factors or formulas used to calculate prices;
 - d) the intention or decision to submit or not to submit, a Tender;
 - e) the submission of a Tender which does not meet the specifications and conditions of the RFP; or
 - f) tendering with the intention of not winning the Tender.

- 4.4 In addition, there have been no consultations, communications, agreements or arrangements with any competitor regarding the quality, quantity, specifications and conditions or delivery particulars of the Goods or Services to which his/her tender relates.
- 4.5 The terms of the Tender as submitted have not been, and will not be, disclosed by the Tenderer, directly or indirectly, to any competitor, prior to the date and time of the official Tender opening or of the awarding of the contract.
- 4.6 Tenderers are aware that, in addition and without prejudice to any other remedy provided to combat any restrictive practices related to Tenders and contracts, Tenders that are suspicious will be reported to the Competition Commission for investigation and possible imposition of administrative penalties in terms of section 59 of the Competition Act No 89 of 1998 and/or may be reported to the National Prosecuting Authority [**NPA**] for criminal investigation and/or may be restricted from conducting business with the public sector for a period not exceeding 10 [ten] years in terms of the Prevention and Combating of Corrupt Activities Act No 12 of 2004 or any other applicable legislation.
- 4.7 Should the Tenderer find any terms or conditions stipulated in any of the relevant documents quoted in the Tender unacceptable, it should indicate which conditions are unacceptable and offer alternatives by written submission on its company letterhead, attached to its submitted Tender. Any such submission shall be subject to review by Transnet's Legal Counsel who shall determine whether the proposed alternative(s) are acceptable or otherwise, as the case may be.

5 DISQUALIFICATION FROM TENDERING PROCESS

- 5.1 If the Tenderer / Service Provider / Contractor has committed a transgression through a violation of section 3 of this Integrity Pact or in any other form such as to put its reliability or credibility as a Tenderer / Service Provider into question, Transnet may reject the Tenderer's / Service Provider's / Contractor's application from the registration or tendering process and remove the Tenderer / Service Provider from its database, if already registered.
- 5.2 If the Tenderer / Service Provider / Contractor has committed a transgression through a violation of section 3, or any material violation, such as to put its reliability or credibility into question. Transnet may after following due procedures and at its own discretion also exclude the Tenderer / Service Provider / Contractor from future tendering processes. The imposition and duration of the exclusion will be determined by the severity of the transgression. The severity will be determined by the circumstances of the case, which will include amongst others the number of transgressions, the position of the transgressors within the company hierarchy of the Tenderer / Service Provider / Contractor and the amount of the damage. The exclusion will be imposed for up to a maximum of 10 (ten)

years. However, Transnet reserves the right to impose a longer period of exclusion, depending on the gravity of the misconduct.

- 5.3 If the Tenderer / Service Provider / Contractor can prove that it has restored the damage caused by it and has installed a suitable corruption prevention system, or taken other remedial measures as the circumstances of the case may require, Transnet may at its own discretion revoke the exclusion or suspend the imposed penalty.

6 TRANSNET'S LIST OF EXCLUDED TENDERERS (BLACKLIST)

- 6.1 All the stipulations around Transnet's blacklisting process as laid down in Transnet's Supply Chain Policy and Procurement Procedures Manual are included herein by way of reference. Below follows a condensed summary of this blacklisting procedure.
- 6.2 Blacklisting is a mechanism used to exclude a company/person from future business with Transnet for a specified period. The decision to blacklist is based on one of the grounds for blacklisting. The standard of proof to commence the blacklisting process is whether a "*prima facie*" (i.e. on the face of it) case has been established.
- 6.3 Depending on the seriousness of the misconduct and the strategic importance of the Goods/Services, in addition to blacklisting a company/person from future business, Transnet may decide to terminate some or all existing contracts with the company/person as well.
- 6.4 A Service Provider or Contractor to Transnet may not subcontract any portion of the contract to a blacklisted company.
- 6.5 Grounds for blacklisting include: If any person/Enterprise which has submitted a Tender, concluded a contract, or, in the capacity of agent or subcontractor, has been associated with such Tender or contract:
- a) Has, in bad faith, withdrawn such Tender after the advertised closing date and time for the receipt of Tenders;
 - b) has, after being notified of the acceptance of his Tender, failed or refused to sign a contract when called upon to do so in terms of any condition forming part of the Tender documents;
 - c) has carried out any contract resulting from such Tender in an unsatisfactory manner or has breached any condition of the contract;
 - d) has offered, promised or given a bribe in relation to the obtaining or execution of the contract;

- e) has acted in a fraudulent or improper manner or in bad faith towards Transnet or any Government Department or towards any public body, Enterprise or person;
- f) has made any incorrect statement in a certificate or other communication with regard to the Local Content of his Goods or his B-BBEE status and is unable to prove to the satisfaction of Transnet that:
 - (i) he made the statement in good faith honestly believing it to be correct; and
 - (ii) before making such statement he took all reasonable steps to satisfy himself of its correctness;
- g) caused Transnet damage, or to incur costs in order to meet the contractor's requirements and which could not be recovered from the contractor;
- h) has litigated against Transnet in bad faith.

6.6 Grounds for blacklisting include a company/person recorded as being a company or person prohibited from doing business with the public sector on National Treasury's database of Restricted Service Providers or Register of Tender Defaulters.

6.7 Companies associated with the person/s guilty of misconduct (i.e. entities owned, controlled or managed by such persons), any companies subsequently formed by the person(s) guilty of the misconduct and/or an existing company where such person(s) acquires a controlling stake may be considered for blacklisting. The decision to extend the blacklist to associated companies will be at the sole discretion of Transnet.

7 PREVIOUS TRANSGRESSIONS

7.1 The Tenderer / Service Provider /Contractor hereby declares that no previous transgressions resulting in a serious breach of any law, including but not limited to, corruption, fraud, theft, extortion and contraventions of the Competition Act 89 of 1998, which occurred in the last 5 (five) years with any other public sector undertaking, government department or private sector company that could justify its exclusion from its registration on the Tenderer's / Service Provider's / Contractor's database or any tendering process.

7.2 If it is found to be that the Tenderer / Service Provider /Contractor made an incorrect statement on this subject, the Tenderer / Service Provider / Contractor can be rejected from the registration process or removed from the Tenderer / Service Provider / Contractor database, if already registered, for such reason (refer to the Breach of Law Form contained in the applicable RFX document.)

8 SANCTIONS FOR VIOLATIONS

- 8.1 Transnet shall also take all or any one of the following actions, wherever required to:
- a) Immediately exclude the Tenderer / Service Provider / Contractor from the tendering process or call off the pre-contract negotiations without giving any compensation the Tenderer / Service Provider / Contractor. However, the proceedings with the other Tenderer / Service Provider / Contractor may continue;
 - b) Immediately cancel the contract, if already awarded or signed, without giving any compensation to the Tenderer / Service Provider / Contractor;
 - c) Recover all sums already paid by Transnet;
 - d) Encash the advance bank guarantee and performance bond or warranty bond, if furnished by the Tenderer / Service Provider / Contractor, in order to recover the payments, already made by Transnet, along with interest;
 - e) Cancel all or any other contracts with the Tenderer / Service Provider; and
 - f) Exclude the Tenderer / Service Provider / Contractor from entering into any Tender with Transnet in future.

9 CONFLICTS OF INTEREST

- 9.1 A conflict of interest includes, inter alia, a situation in which:
- a) A Transnet employee has a personal financial interest in a tendering / supplying entity; and
 - b) A Transnet employee has private interests or personal considerations or has an affiliation or a relationship which affects, or may affect, or may be perceived to affect his / her judgment in action in the best interest of Transnet, or could affect the employee's motivations for acting in a particular manner, or which could result in, or be perceived as favouritism or nepotism.
- 9.2 A Transnet employee uses his / her position, or privileges or information obtained while acting in the capacity as an employee for:
- a) Private gain or advancement; or
 - b) The expectation of private gain, or advancement, or any other advantage accruing to the employee must be declared in a prescribed form.
- Thus, conflicts of interest of any Tender committee member or any person involved in the sourcing process must be declared in a prescribed form.
- 9.3 If a Tenderer / Service Provider / Contractor has or becomes aware of a conflict of interest i.e. a family, business and / or social relationship between its owner(s) / member(s) / director(s) / partner(s) / shareholder(s) and a Transnet employee / member of Transnet's Board of Directors in respect of a Tender which will be considered for the Tender process, the Tenderer / Service Provider / Contractor:
- a) must disclose the interest and its general nature, in the Request for Proposal ("RFX") declaration form; or

b) must notify Transnet immediately in writing once the circumstances has arisen.

9.4 The Tenderer / Service Provider / Contractor shall not lend to or borrow any money from or enter into any monetary dealings or transactions, directly or indirectly, with any committee member or any person involved in the sourcing process, where this is done, Transnet shall be entitled forthwith to rescind the contract and all other contracts with the Tenderer / Service Provider / Contractor.

10 MONITORING

10.1 Transnet will be responsible for appointing an independent Monitor to:

- a) Conduct random monitoring of compliance to the provisions of this Integrity Pact for contracts entered into between Transnet and the Tenderer / Service Provider / Contractor for less than R100,000.000 (one hundred million Rand) in value;
- b) Monitor compliance to the provisions of this Integrity Pact for contracts entered into between Transnet and the Tenderer / Service Provider / Contractor for greater than R100,000.000 (one hundred million Rand) in value; and
- c) Investigate any allegation of violation of any provisions of this Integrity Pact for contracts entered into between Transnet and the Tenderer / Service Provider / Contractor, irrespective of value.

10.2 The Monitor will be subjected to Transnet's Terms of Conditions of Contract for the Provision of Services to Transnet, as well as to Transnet's Service Provider Code of Conduct.

11 EXAMINATION OF FINANCIAL RECORDS, DOCUMENTATION AND/OR ELECTRONIC DATA

For the purpose of Monitoring, as stipulated above, the Monitor shall be entitled to:

- a) Examine the financial records, documentation and or electronic data of Tenderer / Service Provider / Contractor / Transnet. The Tenderer / Service Provider / Transnet shall provide all requested information / documentation / data to the Monitor and shall extend all help possible for the purpose of such examination.

12 DISPUTE RESOLUTION

12.1 Transnet recognises that trust and good faith are pivotal to its relationship with its Tenderer / Service Provider / Contractor. When a dispute arises between Transnet and its Tenderer / Service Provider / Contractor, the parties should use their best endeavours to resolve the dispute in an amicable manner, whenever possible. Litigation in bad faith negates the principles of trust and good faith on which commercial relationships are based. Accordingly, following a blacklisting process as mentioned in paragraph 6 above, Transnet will not do business with a company that litigates against it in bad faith or is involved in any action that

reflects bad faith on its part. Litigation in bad faith includes, but is not limited to the following instances:

- a) **Vexatious proceedings:** these are frivolous proceedings which have been instituted without proper grounds;
- b) **Perjury:** where a Tenderer / Service Provider / Contractor make a false statement either in giving evidence or on an affidavit;
- c) **Scurrilous allegations:** where a Tenderer / Service Provider / Contractor makes allegations regarding a senior Transnet employee which are without proper foundation, scandalous, abusive or defamatory; and
- d) **Abuse of court process:** when a Tenderer / Service Provider / Contractor abuses the court process in order to gain a competitive advantage during a Tender process.

13 GENERAL

13.1 This Integrity Pact is governed by and interpreted in accordance with the laws of the Republic of South Africa.

13.2 The actions stipulated in this Integrity Pact are without prejudice to any other legal action that may follow in accordance with the provisions of the law relating to any civil or criminal proceedings.

13.3 The validity of this Integrity Pact shall cover all the tendering processes and will be valid for an indefinite period unless cancelled by either Party.

13.4 Should one or several provisions of this Integrity Pact turn out to be invalid the remainder of this Integrity Pact remains valid.

13.5 Should a Tenderer / Service Provider / Contractor be confronted with dishonest, fraudulent or corruptive behaviour of one or more Transnet employees, Transnet expects its Tenderer / Service Provider / Contractor to report this behaviour directly to a senior Transnet official / employee or alternatively by using Transnet's "Tip-Off Anonymous" hotline number 0800 003 056, whereby your confidentiality is guaranteed.

The Parties hereby declare that each of them has read and understood the clauses of this Integrity Pact and shall a Tenderer by it. To the best of the Parties' knowledge and belief, the information provided in this Integrity Pact is true and correct.



T2.2-16: RFP DECLARATION FORM

NAME OF COMPANY: _____

We _____ do hereby certify that:

1. Transnet has supplied and we have received appropriate tender offers to any/all questions (as applicable) which were submitted by ourselves for tender clarification purposes;
2. we have received all information we deemed necessary for the completion of this Tender;
3. at no stage have we received additional information relating to the subject matter of this tender from Transnet sources, other than information formally received from the designated Transnet contact(s) as nominated in the tender documents;
4. we are satisfied, insofar as our company is concerned, that the processes and procedures adopted by Transnet in issuing this tender and the requirements requested from tenderers in responding to this tender have been conducted in a fair and transparent manner; and
5. furthermore, we acknowledge that a direct relationship exists between a family member and/or an owner / member / director / partner / shareholder (unlisted companies) of our company and an employee or board member of the Transnet Group as indicated below:

[Respondent to indicate if this section is not applicable]

FULL NAME OF OWNER/MEMBER/DIRECTOR/
PARTNER/SHAREHOLDER:

ADDRESS:

Indicate nature of relationship with Transnet:

[Failure to furnish complete and accurate information in this regard may lead to the disqualification of your response and may preclude a Respondent from doing future business with Transnet]



We declare, to the extent that we are aware or become aware of any relationship between ourselves and Transnet (other than any existing and appropriate business relationship with Transnet) which could unfairly advantage our company in the forthcoming adjudication process, we shall notify Transnet immediately in writing of such circumstances.

6. We accept that any dispute pertaining to this tender will be resolved through the Ombudsman process and will be subject to the Terms of Reference of the Ombudsman. The Ombudsman process must first be exhausted before judicial review of a decision is sought. (Refer "Important Notice to respondents" below).
7. We further accept that Transnet reserves the right to reverse a tender award or decision based on the recommendations of the Ombudsman without having to follow a formal court process to have such award or decision set aside.
8. We have acquainted ourselves and agree with the content of T2.2-22 "Service Provider Integrity Pact".

For and on behalf of duly authorised thereto
Name:
Signature:
Date:

IMPORTANT NOTICE TO TENDERERS

- Transnet has appointed a Procurement Ombudsman to investigate any material complaint in respect of tenders exceeding R5,000,000.00 (five million S.A. Rand) in value. Should a Tenderer have any material concern regarding an tender process which meets this value threshold, a complaint may be lodged with Transnet’s Procurement Ombudsman for further investigation.
- It is incumbent on the Tenderer to familiarise himself/herself with the Terms of Reference for the Transnet Procurement Ombudsman, details of which are available for review at Transnet’s website www.transnet.net.
- An official complaint form may be downloaded from this website and submitted, together with any supporting documentation, within the prescribed period, to procurement.ombud@transnet.net



- For transactions below the R5,000,000.00 (five million S.A. Rand) threshold, a complaint may be lodged with the Chief Procurement Officer of the relevant Transnet Operating Division.
- All Tenderers should note that a complaint must be made in good faith. If a complaint is made in bad faith, Transnet reserves the right to place such a tenderer on its List of Excluded Bidders.



T2.2-17: REQUEST FOR PROPOSAL – BREACH OF LAW

NAME OF COMPANY: _____

I / We _____ do hereby certify that ***I/we have/have not been*** found guilty during the preceding 5 (five) years of a serious breach of law, including but not limited to a breach of the Competition Act, 89 of 1998, by a court of law, tribunal or other administrative body. The type of breach that the Tenderer is required to disclose excludes relatively minor offences or misdemeanours, e.g. traffic offences.

Where found guilty of such a serious breach, please disclose:

NATURE OF BREACH:

DATE OF BREACH:

Furthermore, I/we acknowledge that Transnet SOC Ltd reserves the right to exclude any Tenderer from the tendering process, should that person or company have been found guilty of a serious breach of law, tribunal or regulatory obligation.

Signed on this _____ day of _____ 20____

SIGNATURE OF TENDER



T2.2-18 NON-DISCLOSURE AGREEMENT



Note to tenderers: This Non-Disclosure Agreement is to be completed and signed by an authorised signatory:

THIS AGREEMENT is made effective as of day of 20..... by and between:

TRANSNET SOC LTD

(Registration No. 1990/000900/30), a company incorporated and existing under the laws of South Africa, having its principal place of business at 2nd Floor, Waterfall Business Estate, 9 Country Estate Drive, Midrand, 1662, South Africa

and

.....
.....

(Registration No.), a private company incorporated and existing under the laws of South Africa having its principal place of business at

.....
.....
.....
.....

WHEREAS

Transnet and the Company wish to exchange Information [as defined below] and it is envisaged that each party may from time to time receive Information relating to the other in respect thereof. In consideration of each party making available to the other such Information, the parties jointly agree that any dealings between them shall be subject to the terms and conditions of this Agreement which themselves will be subject to the parameters of the Tender Document.

IT IS HEREBY AGREED

1. INTERPRETATION

In this Agreement:

- 1.1 **Agents** mean directors, officers, employees, agents, professional advisers, contractors or sub-contractors, or any Group member;
- 1.2 **Bid or Bid Document** (hereinafter Tender) means Transnet’s Request for Information [**RFI**] Request for Proposal [**RFP**] or Request for Quotation [**RFQ**], as the case may be;

1.3 **Confidential Information** means any information or other data relating to one party [the **Disclosing Party**] and/or the business carried on or proposed or intended to be carried on by that party and which is made available for the purposes of the Bid to the other party [the **Receiving Party**] or its Agents by the Disclosing Party or its Agents or recorded in agreed minutes following oral disclosure and any other information otherwise made available by the Disclosing Party or its Agents to the Receiving Party or its Agents, whether before, on or after the date of this Agreement, and whether in writing or otherwise, including any information, analysis or specifications derived from, containing or reflecting such information but excluding information which:

1.3.1 is publicly available at the time of its disclosure or becomes publicly available [other than as a result of disclosure by the Receiving Party or any of its Agents contrary to the terms of this Agreement]; or

1.3.2 was lawfully in the possession of the Receiving Party or its Agents [as can be demonstrated by its written records or other reasonable evidence] free of any restriction as to its use or disclosure prior to its being so disclosed; or

1.3.3 following such disclosure, becomes available to the Receiving Party or its Agents [as can be demonstrated by its written records or other reasonable evidence] from a source other than the Disclosing Party or its Agents, which source is not bound by any duty of confidentiality owed, directly or indirectly, to the Disclosing Party in relation to such information;

1.4 **Group** means any subsidiary, any holding company and any subsidiary of any holding company of either party; and

1.5 **Information** means all information in whatever form including, without limitation, any information relating to systems, operations, plans, intentions, market opportunities, know-how, trade secrets and business affairs whether in writing, conveyed orally or by machine-readable medium.

2. CONFIDENTIAL INFORMATION

2.1 All Confidential Information given by one party to this Agreement [the **Disclosing Party**] to the other party [the **Receiving Party**] will be treated by the Receiving Party as secret and confidential and will not, without the Disclosing Party's written consent, directly or indirectly communicate or disclose [whether in writing or orally or in any other manner] Confidential Information to any other person other than in accordance with the terms of this Agreement.

2.2 The Receiving Party will only use the Confidential Information for the sole purpose of technical and commercial discussions between the parties in relation to the Tender or for the subsequent performance of any contract between the parties in relation to the Tender.

2.3 Notwithstanding clause 2.1 above, the Receiving Party may disclose Confidential Information:

- 2.3.1 to those of its Agents who strictly need to know the Confidential Information for the sole purpose set out in clause 2.2 above, provided that the Receiving Party shall ensure that such Agents are made aware prior to the disclosure of any part of the Confidential Information that the same is confidential and that they owe a duty of confidence to the Disclosing Party. The Receiving Party shall at all times remain liable for any actions of such Agents that would constitute a breach of this Agreement; or
- 2.3.2 to the extent required by law or the rules of any applicable regulatory authority, subject to clause 2.4 below.
- 2.4 In the event that the Receiving Party is required to disclose any Confidential Information in accordance with clause 2.3.2 above, it shall promptly notify the Disclosing Party and cooperate with the Disclosing Party regarding the form, nature, content and purpose of such disclosure or any action which the Disclosing Party may reasonably take to challenge the validity of such requirement.
- 2.5 In the event that any Confidential Information shall be copied, disclosed or used otherwise than as permitted under this Agreement then, upon becoming aware of the same, without prejudice to any rights or remedies of the Disclosing Party, the Receiving Party shall as soon as practicable notify the Disclosing Party of such event and if requested take such steps [including the institution of legal proceedings] as shall be necessary to remedy [if capable of remedy] the default and/or to prevent further unauthorised copying, disclosure or use.
- 2.6 All Confidential Information shall remain the property of the Disclosing Party and its disclosure shall not confer on the Receiving Party any rights, including intellectual property rights over the Confidential Information whatsoever, beyond those contained in this Agreement.

3. RECORDS AND RETURN OF INFORMATION

- 3.1 The Receiving Party agrees to ensure proper and secure storage of all Information and any copies thereof.
- 3.2 The Receiving Party shall keep a written record, to be supplied to the Disclosing Party upon request, of the Confidential Information provided and any copies made thereof and, so far as is reasonably practicable, of the location of such Confidential Information and any copies thereof.
- 3.3 The Company shall, within 7 [seven] days of receipt of a written demand from Transnet:
- 3.3.1 return all written Confidential Information [including all copies]; and
- 3.3.2 expunge or destroy any Confidential Information from any computer, word processor or other device whatsoever into which it was copied, read or programmed by the Company or on its behalf.
- 3.4 The Company shall on request supply a certificate signed by a director as to its full compliance with the requirements of clause 3.3.2 above.

4. ANNOUNCEMENTS

- 4.1 Neither party will make or permit to be made any announcement or disclosure of its prospective interest in the Tender without the prior written consent of the other party.
- 4.2 Neither party shall make use of the other party's name or any information acquired through its dealings with the other party for publicity or marketing purposes without the prior written consent of the other party.

5. DURATION

The obligations of each party and its Agents under this Agreement shall survive the termination of any discussions or negotiations between the parties regarding the Tender and continue thereafter for a period of 5 [five] years.

6. PRINCIPAL

Each party confirms that it is acting as principal and not as nominee, agent or broker for any other person and that it will be responsible for any costs incurred by it or its advisers in considering or pursuing the Tender and in complying with the terms of this Agreement.

7. ADEQUACY OF DAMAGES

Nothing contained in this Agreement shall be construed as prohibiting the Disclosing Party from pursuing any other remedies available to it, either at law or in equity, for any such threatened or actual breach of this Agreement, including specific performance, recovery of damages or otherwise.

8. PRIVACY AND DATA PROTECTION

- 8.1 The Receiving Party undertakes to comply with South Africa's general privacy protection in terms Section 14 of the Bill of Rights in connection with this Tender and shall procure that its personnel shall observe the provisions of such Act [as applicable] or any amendments and re-enactments thereof and any regulations made pursuant thereto.
- 8.2 The Receiving Party warrants that it and its Agents have the appropriate technical and organisational measures in place against unauthorised or unlawful processing of data relating to the Tender and against accidental loss or destruction of, or damage to such data held or processed by them.



9. GENERAL

- 9.1 Neither party may assign the benefit of this Agreement, or any interest hereunder, except with the prior written consent of the other, save that Transnet may assign this Agreement at any time to any member of the Transnet Group.
- 9.2 No failure or delay in exercising any right, power or privilege under this Agreement will operate as a waiver of it, nor will any single or partial exercise of it preclude any further exercise or the exercise of any right, power or privilege under this Agreement or otherwise.
- 9.3 The provisions of this Agreement shall be severable in the event that any of its provisions are held by a court of competent jurisdiction or other applicable authority to be invalid, void or otherwise unenforceable, and the remaining provisions shall remain enforceable to the fullest extent permitted by law.
- 9.4 This Agreement may only be modified by a written agreement duly signed by persons authorised on behalf of each party.
- 9.5 Nothing in this Agreement shall constitute the creation of a partnership, joint venture or agency between the parties.
- 9.6 This Agreement will be governed by and construed in accordance with South African law and the parties irrevocably submit to the exclusive jurisdiction of the South African courts.

Signed	_____	Date	_____
Name	_____	Position	_____
Tenderer	_____		

T2.2-19 Certificate of Acquaintance with Tender Documents

NAME OF TENDERING ENTITY:

1. By signing this certificate I/we acknowledge that I/we have made myself/ourselves thoroughly familiar with, and agree with all the conditions governing this RFP. This includes those terms and conditions of the Contract, the Supplier Integrity Pact, Non-Disclosure Agreement etc. contained in any printed form stated to form part of the documents thereof, but not limited to those listed in this clause.
2. I/we furthermore agree that Transnet SOC Ltd shall recognise no claim from me/us for relief based on an allegation that I/we overlooked any tender/contract condition or failed to take it into account for the purpose of calculating my/our offered prices or otherwise.
3. I/we understand that the accompanying Tender will be disqualified if this Certificate is found not to be true and complete in every respect.
4. For the purposes of this Certificate and the accompanying Tender, I/we understand that the word "competitor" shall include any individual or organisation, other than the Tenderer, whether or not affiliated with the Tenderer, who:
 - a) has been requested to submit a Tender in response to this Tender invitation;
 - b) could potentially submit a Tender in response to this Tender invitation, based on their qualifications, abilities or experience; and
 - c) provides the same Services as the Tenderer and/or is in the same line of business as the Tenderer
5. The Tenderer has arrived at the accompanying Tender independently from, and without consultation, communication, agreement or arrangement with any competitor. However communication between partners in a joint venture or consortium will not be construed as collusive Tendering.
6. In particular, without limiting the generality of paragraph 5 above, there has been no consultation, communication, agreement or arrangement with any competitor regarding:
 - a) prices;
 - b) geographical area where Services will be rendered [market allocation]

- c) methods, factors or formulas used to calculate prices;
 - d) the intention or decision to submit or not to submit, a Tender;
 - e) the submission of a tender which does not meet the specifications and conditions of the tender; or
 - f) Tendering with the intention not winning the tender.
7. In addition, there have been no consultations, communications, agreements or arrangements with any competitor regarding the quality, quantity, specifications and conditions or delivery particulars of the Services to which this tender relates.
8. The terms of the accompanying tender have not been, and will not be, disclosed by the Tenderer, directly or indirectly, to any competitor, prior to the date and time of the official tender opening or of the awarding of the contract.
9. I/We am/are aware that, in addition and without prejudice to any other remedy provided to combat any restrictive practices related to tenders and contracts, tenders that are suspicious will be reported to the Competition Commission for investigation and possible imposition of administrative penalties in terms of section 59 of the Competition Act No 89 of 1998 and/or may be reported to the National Prosecuting Authority [NPA] for criminal investigation. In addition, Tenderers that submit suspicious tenders may be restricted from conducting business with the public sector for a period not exceeding 10 [ten] years in terms of the Prevention and Combating of Corrupt Activities Act No 12 of 2004 or any other applicable legislation.

Signed on this _____ day of _____ 20____

SIGNATURE OF TENDERER

T2.2-20 SUPPLIER DECLARATION FORM

Transnet Vendor Management has received a request to load / change your company details onto the Transnet vendor master database. Please return the completed Supplier Declaration Form (SDF) together with the required supporting documents as per Appendix A to the Transnet Official who is intending to procure your company's services / products, to enable us to process this request. Please only submit the documentation relevant to your request.

Please Note: all organisations, institutions and individuals who wish to provide goods and/or services to organs of the State must be registered on the National Treasury's Central Supplier Database (CSD). This needs to be done via their portal at <https://secure.csd.gov.za/> **before applying to Transnet.**

General Terms and Conditions:

Please Note: Failure to submit the relevant documentation will delay the vendor creation / change process.

Where applicable, the respective Transnet Operating Division processing your application may request further or additional information from your company.

The Service Provider warrants that the details of its bank account ("the nominated account") provided herein, are correct and acknowledges that payments due to the Supplier will be made into the nominated account. If details of the nominated account should change, the Service Provider must notify Transnet in writing of such change, failing which any payments made by Transnet into the nominated account will constitute a full discharge of the indebtedness of Transnet to the Supplier in respect of the payment so made. Transnet will incur no liability for any payments made to the incorrect account or any costs associated therewith. In such an event, the Service Provider indemnifies and holds Transnet harmless in respect of any payments made to an incorrect bank account and will, on demand, pay Transnet any costs associated herewith.

Transnet expects its suppliers to timeously renew their Tax Clearance and B-BBEE certificates (Large Enterprises and QSEs less than 51% black owned) as well as sworn affidavits in the case of EMEs and QSEs with more than 51% black ownership as per Appendices C and D.

In addition, please take note of the following very important information:

1. If your annual turnover is R10 million or less, then in terms of the DTI Generic Codes of Good Practice, you are classified as an Exempted Micro Enterprise (EME). If your company is classified as an EME, please include in your submission a sworn affidavit confirming your company's most recent annual turnover is less than R10 million and percentage of black ownership and black female ownership in the company (Appendix C) OR B-BBEE certificate issued by a verification agency accredited by SANAS in terms of the EME scorecard should you feel you will be able to attain a better B-BBEE score. It is only in this context that an EME may submit a B-BBEE verification certificate. These EME sworn affidavits must be accepted by the . Government introduced this mechanism specifically to reduce the cost of doing business and regulatory burden for these entities and the template for the sworn affidavit is available at no cost on the website www.thedti.gov.za or EME certificates at CIPC from www.cipic.co.za.

The B-BBEE Commission said "that only time an EME can be verified by a SANAS accredited verification professional is when it wishes to maximise its B-BBEE points and move to a higher B-BBEE recognition level, and that must be done use the QSE Scorecard".

2. If your annual turnover is between R10 million and R50 million, then in terms of the DTI codes, you are classified as a Qualifying Small Enterprise (QSE). A QSE which is at least 51% black owned, is required to submit a sworn affidavit confirming their annual total revenue of between R10 million and R50 million and level of black ownership (Appendix D). QSE that does not qualify for 51% of black ownership, are required to submit a B-BBEE verification certificate issued by a verification agency accredited by SANAS their QSEs are required to submit a B-BBEE verification certificate issued by a verification agency accredited by SANAS.

Please Note: B-BBEE certificate and detailed scorecard should be obtained from an accredited rating agency (e.g. SANAS Member).

3. If your annual turnover exceeds R50 million, then in terms of the DTI codes, you are classified as a Large Enterprise. Large Enterprises are required to submit a B-BBEE level verification certificate issued by a verification agency accredited by SANAS.

Please Note: B-BBEE certificate and detailed scorecard should be obtained from an accredited rating agency (e.g. SANAS Member).

4. The supplier to furnish proof to the procurement department as required in the Fourth Schedule of the Income Tax Act. 58 of 1962 whether a supplier of service is to be classified as an "employee", "personal service provider" or "labour broker". Failure to do so will result in the supplier being subject to employee's tax.

5. **No payments can be made to a vendor until the** vendor has been registered / updated, and no vendor can be registered / updated until the vendor application form, together with its supporting documentation, has been received and processed. No payments can be made to a vendor until the vendor has met / comply with the procurement requirements.

6. It is in line with PPPFA Regulations, only valid B-BBEE status level certificate issued by an unauthorised body or person OR a sworn affidavit as prescribed by the B-BBEE Codes of Good Practice, OR any other requirement prescribed in terms of the Broad- Based Black Economic Empowerment Act.

7. The B-BBEE Commission advises entities and organs of state to reject B-BBEE certificates that have been issued by verification agencies or professionals who are not accredited by South African National Accreditation Systems ("SANAS) as such B-BBEE certificates are invalid for lack of authority and mandate to issue them. A list of SANAS Accredited agencies is available on the SANAS website at www.sanas.co.za.

8. Presenting banking details. Please note: Banks have decided to enable the customers and provide the ability for customers to generate Account Confirmation/Bank Account letters via their online platform; this is a digital approach to the authentication of banking details.

SUPPLIER DECLARATION FORM

Supplier Declaration Form

Important Notice: all organisations, institutions and individuals who wish to provide goods and/or services to organs of the State must be registered on the National Treasury Central Supplier Database (CSD). This needs to be done via their portal at <https://secure.csd.gov.za/> **before applying to Transnet.**

CSD Number (MAAA xxxxxxx):

Company Trading Name						
Company Registered Name						
Company Registration No Or ID No If a Sole Proprietor						
Company Income Tax Number						
Form of Entity	CC	Trust	Pty Ltd	Limited	Partnership	Sole Proprietor
	Non-profit (NPO's or NPC)	Personal Liability Co	State Owned Co	National Govt	Provincial Govt	Local Govt
	Education al Institution	Specialise d Profession	Financial Institution	Joint Venture	Foreign International	Foreign Branch Office

Did your company previously operate under another name?						Yes	No
If YES state the previous details below:							
Trading Name							
Registered Name							
Company Registration No Or ID No If a Sole Proprietor							
Form of Entity	CC	Trust	Pty Ltd	Limited	Partnership	Sole Proprietor	
	Non-profit (NPO's or NPC)	Personal Liability Co	State Owned Co	National Govt	Provincial Govt	Local Govt	
	Education al Institution	Specialise d Profession	Financial Institution	Joint Venture	Foreign International	Foreign Branch Office	

Your Current Company's VAT Registration Status	
VAT Registration Number	
If Exempted from VAT registration , state reason and submit proof from SARS in confirming the exemption status	
If your business entity is not VAT Registered, please submit a current original sworn affidavit (see example in Appendix I). Your Non VAT Registration must be confirmed annually.	

Company Banking Details		Bank Name	
Universal Branch Code		Bank Account Number	

Company Physical Address		Code	
Company Postal Address		Code	
Company Telephone number			
Company Fax Number			
Company E-Mail Address			
Company Website Address			

Company Contact Person Name	
Designation	
Telephone	
Email	

Is your company a Labour Broker?	Yes		No	
Main Product / Service Supplied e.g. Stationery / Consulting / Labour etc.				
How many personnel does the business employ?	Full Time		Part Time	
Please Note: Should your business employ more than 2 full time employees who are not connected persons as defined in the Income Tax Act, please submit a sworn affidavit, as per Appendix II.				

Most recent Financial Year's Annual Turnover	<R10Million EME	>R10Million <R50Million QSE	>R50Million Large Enterprise
--	---------------------------	--	--

Does your company have a valid proof of B-BBEE status?										Yes		No	
Please indicate your Broad Based BEE status (Level 1 to 9)					1	2	3	4	5	6	7	8	9
Majority Race of Ownership													
% Black Ownership		% Black Women Ownership		% Black Disabled person(s) Ownership				% Black Youth Ownership					
% Black Unemployed		% Black People Living in Rural Areas		% Black Military Veterans									

Please Note: Please provide proof of B-BBEE status as per Appendix C and D:

- Large Enterprise and QSEs with less than 51% black ownership need to obtain a B-BBEE certificate and detailed scorecard from an accredited rating agency;
- EMEs and QSEs with at least 51% black ownership may provide an affidavit using the templates provided in Appendix C and D respectively;

- Black Disabled person(s) ownership will only be accepted if accompanied with a certified letter signed by a physician on the physician's letterhead confirming the disability;
- A certified South African identification document will be required for all Black Youth Ownership.

Supplier Development Information Required	
EMPOWERING SUPPLIER An Empowering Supplier is a B-BBEE compliant Entity which complies with at least three criteria if it is a large Entity, or one criterion if it is a Qualifying Small Enterprise ("QSE"), as detailed in Statement 400 of the New Codes. In terms of the requirements of an Empowering Supplier, numerous companies found it challenging to meet the target of 25% transformation of raw materials or beneficiation including local manufacturing, particularly so, if these companies imported goods or products from offshore. The matter was further compounded by the requirement for 25% of Cost of Sales, excluding labour cost and depreciation, to be procured from local producers or suppliers.	YES <input type="radio"/> NO <input type="radio"/>
FIRST TIME SUPPLIER A supplier that we haven't as yet Traded within Transnet and will be registered via our database for the 1 st time.	YES <input type="radio"/> NO <input type="radio"/>
SUPPLIER DEVELOPMENT PLAN Supplier Development Plan is a plan that when we as Transnet award a supplier a long term contract depending on the complexity of the Transaction. We will negotiate supplier development obligations that they must meet throughout the contract duration. e.g. we might request that they (create jobs or do skills development or encourage procurement from designated groups. (BWO, BYO & BDO etc.)).	YES <input type="radio"/> NO <input type="radio"/>
DEVELOPMENT PLAN DOCUMENT Agreed plan that will be crafted with the supplier in regards to their development (It could be for ED OR SD in terms of their developmental needs they may require with the company.	YES <input type="radio"/> NO <input type="radio"/> *If Yes- Attach supporting documents
ENTERPRISE DEVELOPMENT BENEFICIARY A supplier that is not as yet in our value chain that we are assisting in their developmental area.	YES <input type="radio"/> NO <input type="radio"/>
SUPPLIER DEVELOPMENT BENEFICIARY A supplier that we are already doing business with or transacting with and we are also assisting them	YES <input type="radio"/> NO <input type="radio"/>

in their developmental area e.g. (They might require training or financial assistance etc.)	
GRADUATION FROM ED TO SD BENEFICIARY	
When a supplier that we assisted with as an ED beneficiary then gets awarded a business and we start Transacting with.	YES <input type="radio"/> NO <input type="radio"/>
ENTERPRISE DEVELOPMENT RECIPIENT	
A supplier that isn't in our value chain as yet but we have assisted them with an ED intervention	YES <input type="radio"/> NO <input type="radio"/>

By signing below, I hereby verify that I am duly authorised to sign for and on behalf of firm / organisation and that all information contained herein and attached herewith are true and correct			
Name and Surname		Designation	
Signature		Date	



APPENDIX B

Affidavit or Solemn Declaration as to VAT registration status

Affidavit or Solemn Declaration

I, _____ solemnly swear/declare that _____ is not a registered VAT vendor and is not required to register as a VAT vendor because the combined value of taxable supplies made by the provider in any 12 month period has not exceeded or is not expected to exceed R1million threshold, as required in terms of the Value Added Tax Act.

Signature: _____

Designation: _____

Date: _____

Commissioner of Oaths

Thus signed and sworn to before me at _____ on this the _____ day of _____ 20_____,

the Deponent having knowledge that he/she knows and understands the contents of this Affidavit, and that he/she has no objection to taking the prescribed oath, which he/she regards binding on his/her conscience and that the allegations herein contained are all true and correct.

Commissioner of Oaths

APPENDIX C

SWORN AFFIDAVIT – B-BBEE QUALIFYING SMALL ENTERPRISE – GENERAL

I, the undersigned,

Full name & Surname	
Identity number	

Hereby declare under oath as follows:

1. The contents of this statement are to the best of my knowledge a true reflection of the facts.

2. I am a Member / Director / Owner of the following enterprise and am duly authorised to act on its behalf:

Enterprise Name:	
Trading Name (If Applicable):	
Registration Number:	
Enterprise Physical Address:	
Type of Entity (CC, (Pty) Ltd, Sole Prop etc.):	
Nature of Business:	
Definition of "Black People"	As per the Broad-Based Black Economic Empowerment Act 53 of 2003 as Amended by Act No 46 of 2013 "Black People" is a generic term which means Africans, Coloureds and Indians – (a) who are citizens of the Republic of South Africa by birth or descent; or (b) who became citizens of the Republic of South Africa by naturalisation- i. before 27 April 1994; or ii. on or after 27 April 1994 and who would have been entitled to acquire citizenship by naturalization prior to that date;"
Definition of "Black"	Black Designated Groups means:



Designated Groups"	<p>(a) unemployed black people not attending and not required by law to attend an educational institution and not awaiting admission to an educational institution;</p> <p>(b) Black people who are youth as defined in the National Youth Commission Act of 1996;</p> <p>(c) Black people who are persons with disabilities as defined in the Code of Good Practice on employment of people with disabilities issued under the Employment Equity Act;</p> <p>(d) Black people living in rural and under developed areas;</p> <p>(e) Black military veterans who qualifies to be called a military veteran in terms of the Military Veterans Act 18 of 2011;"</p>
---------------------------	---

3. I hereby declare under Oath that:

- The Enterprise is _____% Black Owned as per Amended Code Series 100 of the Amended Codes of Good Practice issued under section 9 (1) of B-BBEE Act No 53 of 2003 as Amended by Act No 46 of 2013,
- The Enterprise is _____% Black Female Owned as per Amended Code Series 100 of the Amended Codes of Good Practice issued under section 9 (1) of B-BBEE Act No 53 of 2003 as Amended by Act No 46 of 2013,
- The Enterprise is _____% Black Designated Group Owned as per Amended Code Series 100 of the Amended Codes of Good Practice issued under section 9 (1) of B-BBEE Act No 53 of 2003 as Amended by Act No 46 of 2013,

- Black Designated Group Owned % Breakdown as per the definition stated above:

- Black Youth % = _____%
- Black Disabled % = _____%
- Black Unemployed % = _____%
- Black People living in Rural areas % = _____%
- Black Military Veterans % = _____%

- Based on the Financial Statements/Management Accounts and other information available on

the latest financial year-end of _____, the annual Total Revenue was

between

R10,000,000.00 (Ten Million Rands) and R50,000,000.00 (Fifty Million Rands),



- Please confirm on the table below the B-BBEE level contributor, **by ticking the applicable box.**

100% Black Owned	Level One (135% B-BBEE procurement recognition level)	
At Least 51% black owned	Level Two (125% B-BBEE procurement recognition level)	

4. I know and understand the contents of this affidavit and I have no objection to take the prescribed oath and consider the oath binding on my conscience and on the owners of the enterprise which I represent in this matter.

5. The sworn affidavit will be valid for a period of 12 months from the date signed by commissioner.

Deponent Signature

.....

Date

.....

Commissioner of Oaths

Signature & stamp

APPENDIX D

SWORN AFFIDAVIT – B-BBEE EXEMPTED MICRO ENTERPRISE – GENERAL

I, the undersigned,

Full name & Surname	
Identity number	

Hereby declare under oath as follows:

1. The contents of this statement are to the best of my knowledge a true reflection of the facts.
2. I am a Member / Director / Owner of the following enterprise and am duly authorised to act on its behalf:

Enterprise Name:	
Trading Name (If Applicable):	
Registration Number:	
Enterprise Physical Address:	
Type of Entity (CC, (Pty) Ltd, Sole Prop etc.):	
Nature of Business:	
Definition of "Black People"	As per the Broad-Based Black Economic Empowerment Act 53 of 2003 as Amended by Act No 46 of 2013 "Black People" is a generic term which means Africans, Coloureds and Indians – (a) who are citizens of the Republic of South Africa by birth or descent; or



	<p>(b) who became citizens of the Republic of South Africa by naturalisation-</p> <p>i. before 27 April 1994; or</p> <p>ii. on or after 27 April 1994 and who would have been entitled to acquire citizenship by naturalization prior to that date;”</p>
<p>Definition of “Black Designated Groups”</p>	<p>“Black Designated Groups means:</p> <p>(a) unemployed black people not attending and not required by law to attend an educational institution and not awaiting admission to an educational institution;</p> <p>(b) Black people who are youth as defined in the National Youth Commission Act of 1996;</p> <p>(c) Black people who are persons with disabilities as defined in the Code of Good Practice on employment of people with disabilities issued under the Employment Equity Act;</p> <p>(d) Black people living in rural and under developed areas;</p> <p>(e) Black military veterans who qualifies to be called a military veteran in terms of the Military Veterans Act 18 of 2011;”</p>

3. I hereby declare under Oath that:

- The Enterprise is _____% Black Owned as per Amended Code Series 100 of the Amended Codes of Good Practice issued under section 9 (1) of B-BBEE Act No 53 of 2003 as Amended by Act No 46 of 2013,
- The Enterprise is _____% Black Female Owned as per Amended Code Series 100 of the Amended Codes of Good Practice issued under section 9 (1) of B-BBEE Act No 53 of 2003 as Amended by Act No 46 of 2013,
- The Enterprise is _____% Black Designated Group Owned as per Amended Code Series 100 of the Amended Codes of Good Practice issued under section 9 (1) of B-BBEE Act No 53 of 2003 as Amended by Act No 46 of 2013,
- Black Designated Group Owned % Breakdown as per the definition stated above:
- Black Youth % = _____%
- Black Disabled % = _____%
- Black Unemployed % = _____%



- Black People living in Rural areas % = _____%
- Black Military Veterans % = _____%

- Based on the Financial Statements/Management Accounts and other information available on the latest financial year-end of _____, the annual Total Revenue was R10,000,000.00 (Ten Million Rands) or less

- Please Confirm on the below table the B-BBEE Level Contributor, **by ticking the applicable box.**

100% Black Owned	Level One (135% B-BBEE procurement recognition)	
At least 51% Black Owned	Level Two (125% B-BBEE procurement recognition level)	
Less than 51% Black Owned	Level Four (100% B-BBEE procurement recognition level)	

4. I know and understand the contents of this affidavit and I have no objection to take the prescribed oath and consider the oath binding on my conscience and on the Owners of the Enterprise which I represent in this matter.

5. The sworn affidavit will be valid for a period of 12 months from the date signed by commissioner.

Deponent Signature

.....

Date

.....

Commissioner of Oaths

Signature & stamp



VENDOR REGISTRATION DOCUMENTS CHECKLIST

Please note that you will have to provide the first two documents on the list (highlighted in red) and the rest will be provided by the supplier:

	Yes	No
1. Complete the "Supplier Declaration Form" (SDF) (commissioned). See attachment.		
2. Complete the "Supplier Code of Conduct" (SCC). See attachment.		
3. Copy of cancelled cheque OR letter from the bank verifying banking details (with bank stamp not older than 3 Months & sign by Bank Teller).		
4. Certified (Not Older than 3 Months) copy of Identity document of Shareholders/Directors/Members (where applicable).		
5. Certified copy of certificate of incorporation, CM29 / CM9 (name change).		
6. Certified copy of share Certificates of Shareholders, CK1 / CK2 (if CC).		
7. A letter with the company's letterhead confirming both Physical and Postal address.		
8. Original or certified copy of SARS Tax Clearance certificate and Vat registration certificate.		
9. BBBEE certificate and detailed scorecard from a SANAS Accredited Verification Agency and/or Sworn Certified Affidavit.		
10. Central Supplier Database (CSD) Summary Registration Report.		



T2.2-21: SBD1 (TAX COMPLIANCE STATUS)

PART A: INVITATION TO BID

YOU ARE HEREBY INVITED TO BID FOR REQUIREMENTS OF TRANSNET FREIGHT RAIL, A DIVISION TRANSNET SOC LTD							
BID NUMBER:	SIG20030CIDB (HOAC-HO-34780)	ISSUE DATE:	10 September 2021	CLOSING DATE:	14 October 2021	CLOSING TIME:	10H00
DESCRIPTION	Renovation of Main General Buildings (GB CIBD) at various Transnet Freight Rail Depots across Eastern Region for a period of 06 Months. (Koedoespoort)						
BID RESPONSE DOCUMENTS MAY BE DEPOSITED IN THE BID BOX SITUATED AT (STREET ADDRESS)							
Tender Advice Centre							
Tender Advice Centre,							
Ground Floor, Inyanda House 1,							
21 Wellington Road, Parktown, Johannesburg							
BIDDING PROCEDURE ENQUIRIES MAY BE DIRECTED TO				TECHNICAL ENQUIRIES MAY BE DIRECTED TO:			
CONTACT PERSON	Delisiwe Mngomezulu			CONTACT PERSON	Sibusiso Mazibuko		
TELEPHONE NUMBER	011 584-1129			TELEPHONE NUMBER	011 773 / 083 288 9502		
FACSIMILE NUMBER	n/a			FACSIMILE NUMBER	n/a		
E-MAIL ADDRESS	Delisiwe.Mngomezulu@transnet.net			E-MAIL ADDRESS	Sibusiso.Mazibuko@transnet.net		
SUPPLIER INFORMATION							
NAME OF BIDDER							
POSTAL ADDRESS							
STREET ADDRESS							
TELEPHONE NUMBER	CODE			NUMBER			
CELLPHONE NUMBER							
FACSIMILE NUMBER	CODE			NUMBER			
E-MAIL ADDRESS							
VAT REGISTRATION NUMBER							
SUPPLIER COMPLIANCE STATUS	TAX COMPLIANCE SYSTEM PIN:		OR	CENTRAL SUPPLIER DATABASE	UNIQUE REGISTRATION REFERENCE NUMBER:	MAAA	
B-BBEE STATUS LEVEL VERIFICATION CERTIFICATE	TICK APPLICABLE BOX] <input type="checkbox"/> Yes <input type="checkbox"/> No			B-BBEE STATUS LEVEL SWORN AFFIDAVIT	[TICK APPLICABLE BOX] <input type="checkbox"/> Yes <input type="checkbox"/> No		
[A B-BBEE STATUS LEVEL VERIFICATION CERTIFICATE/ SWORN AFFIDAVIT (FOR EMES & QSEs) MUST BE SUBMITTED IN ORDER TO QUALIFY FOR PREFERENCE POINTS FOR B-BBEE]							



<p>1 ARE YOU THE ACCREDITED REPRESENTATIVE IN SOUTH AFRICA FOR THE GOODS /SERVICES /WORKS OFFERED?</p> <p><input type="checkbox"/>Yes <input type="checkbox"/>No</p> <p>[IF YES ENCLOSE PROOF]</p>	<p>2 ARE YOU A FOREIGN BASED SUPPLIER FOR THE GOODS /SERVICES /WORKS OFFERED?</p> <p><input type="checkbox"/>Yes <input type="checkbox"/>No</p> <p>[IF YES, ANSWER QUESTIONNAIRE BELOW]</p>
---	--

QUESTIONNAIRE TO BIDDING FOREIGN SUPPLIERS

IS THE ENTITY A RESIDENT OF THE REPUBLIC OF SOUTH AFRICA (RSA)?	<input type="checkbox"/> YES <input type="checkbox"/> NO
DOES THE ENTITY HAVE A BRANCH IN THE RSA?	<input type="checkbox"/> YES <input type="checkbox"/> NO
DOES THE ENTITY HAVE A PERMANENT ESTABLISHMENT IN THE RSA?	<input type="checkbox"/> YES <input type="checkbox"/> NO
DOES THE ENTITY HAVE ANY SOURCE OF INCOME IN THE RSA?	<input type="checkbox"/> YES <input type="checkbox"/> NO
IS THE ENTITY LIABLE IN THE RSA FOR ANY FORM OF TAXATION?	<input type="checkbox"/> YES <input type="checkbox"/> NO

IF THE ANSWER IS "NO" TO ALL OF THE ABOVE, THEN IT IS NOT A REQUIREMENT TO REGISTER FOR A TAX COMPLIANCE STATUS SYSTEM PIN CODE FROM THE SOUTH AFRICAN REVENUE SERVICE (SARS) AND IF NOT REGISTER AS PER 1.3 BELOW.

**PART B
 TERMS AND CONDITIONS FOR BIDDING**

1. TAX COMPLIANCE REQUIREMENTS

- 1.1 BIDDERS MUST ENSURE COMPLIANCE WITH THEIR TAX OBLIGATIONS.
- 1.2 BIDDERS ARE REQUIRED TO SUBMIT THEIR UNIQUE PERSONAL IDENTIFICATION NUMBER (PIN) ISSUED BY SARS TO ENABLE THE ORGAN OF STATE TO VERIFY THE TAXPAYER'S PROFILE AND TAX STATUS.
- 1.3 APPLICATION FOR TAX COMPLIANCE STATUS (TCS) PIN MAY BE MADE VIA E-FILING THROUGH THE SARS WEBSITE WWW.SARS.GOV.ZA.
- 1.4 BIDDERS MAY ALSO SUBMIT A PRINTED TCS CERTIFICATE TOGETHER WITH THE BID.
- 1.5 IN BIDS WHERE UNINCORPORATED CONSORTIA / JOINT VENTURES / SUB-CONTRACTORS ARE INVOLVED, EACH PARTY MUST SUBMIT A SEPARATE TCS CERTIFICATE / PIN / CSD NUMBER.
- 1.6 WHERE NO TCS IS AVAILABLE BUT THE BIDDER IS REGISTERED ON THE CENTRAL SUPPLIER DATABASE (CSD), A CSD NUMBER MUST BE PROVIDED.

NB: FAILURE TO PROVIDE / OR COMPLY WITH ANY OF THE ABOVE PARTICULARS MAY RENDER THE BID INVALID.

SIGNATURE OF BIDDER:

CAPACITY UNDER WHICH THIS BID IS SIGNED:

(Proof of authority must be submitted e.g. company resolution)

DATE: _____

T2.2-22: Insurance provided by the *Contractor*

Clause 84.1 in NEC3 Engineering & Construction Contract (June 2005)(amended June 2006 and April 2013) requires that the *Contractor* provides the insurance stated in the insurance table except any insurance which the *Employer* is to provide as stated in the Contract Data.

Please provide the following details for insurance which the *Contractor* is still to provide. Notwithstanding this information all costs related to insurance are deemed included in the tenderer's rates and prices.

Insurance against (See clause 84.2 of the ECC)	Name of Insurance Company	Cover	Premium
Liability for death of or bodily injury to employees of the <i>Contractor</i> arising out of and in the course of their employment in connection with this contract			
Motor Vehicle Liability Insurance comprising (as a minimum) "Balance of Third Party" Risks including Passenger and Unauthorised Passenger Liability indemnity with a minimum indemnity limit of R5 000 000/R10 000 000.			
Insurance in respect of loss of or damage to own property and equipment.			
(Other)			



T2.2-23: Three (3) years audited financial statements

Attached to this schedule is the last three (3) years audited financial statements of the single tenderer/members of the Joint Venture.

NAME OF COMPANY/IES and INDEX OF ATTACHMENTS:

.....

.....

.....

.....

.....

.....

.....

.....



C1.1: Form of Offer & Acceptance

Offer

The Employer, identified in the Acceptance signature block, has solicited offers to enter into a contract for the procurement of:

RENOVATION OF MAIN GENERAL BUILDINGS (GB CIBD) AT VARIOUS TRANSNET FREIGHT RAIL DEPOTS ACROSS EASTERN REGION FOR A PERIOD OF 06 MONTHS.

The tenderer, identified in the Offer signature block, has

examined the documents listed in the Tender Data and addenda thereto as listed in the Returnable Schedules, and by submitting this Offer has accepted the Conditions of Tender.

By the representative of the tenderer, deemed to be duly authorised, signing this part of this Form of Offer and Acceptance the tenderer offers to perform all of the obligations and liabilities of the *Contractor* under the contract including compliance with all its terms and conditions according to their true intent and meaning for an amount to be determined in accordance with the *conditions of contract* identified in the Contract Data.

The offered total of the Prices exclusive of VAT is	R
Value Added Tax @ 15% is	R
The offered total of the Prices inclusive of VAT is	R
(in words)	

This Offer may be accepted by the Employer by signing the Acceptance part of this Form of Offer and Acceptance and returning one copy of this document including the Schedule of Deviations (if any) to the tenderer before the end of the period of validity stated in the Tender Data, or other period as agreed, whereupon the tenderer becomes the party named as the *Contractor* in the *conditions of contract* identified in the Contract Data.

Signature(s)

Name(s)

Capacity

For the tenderer:

Name & signature of witness

(Insert name and address of organisation)

Date

Tenderer's CIDB registration number:

Acceptance

By signing this part of this Form of Offer and Acceptance, the *Employer* identified below accepts the tenderer's Offer. In consideration thereof, the *Employer* shall pay the *Contractor* the amount due in accordance with the *conditions of contract* identified in the Contract Data. Acceptance of the tenderer's Offer shall form an agreement between the *Employer* and the tenderer upon the terms and conditions contained in this agreement and in the contract that is the subject of this agreement.

The terms of the contract, are contained in:

Part C1	Agreements and Contract Data, (which includes this Form of Offer and Acceptance)
Part C2	Pricing Data
Part C3	Scope of Work: Works Information
Part C4	Site Information

and drawings and documents (or parts thereof), which may be incorporated by reference into the above listed Parts.

Deviations from and amendments to the documents listed in the Tender Data and any addenda thereto listed in the Returnable Schedules as well as any changes to the terms of the Offer agreed by the tenderer and the Employer during this process of offer and acceptance, are contained in the Schedule of Deviations attached to and forming part of this Form of Offer and Acceptance. No amendments to or deviations from said documents are valid unless contained in this Schedule.

The tenderer shall within two weeks of receiving a completed copy of this agreement, including the Schedule of Deviations (if any), contact the Employer's agent (whose details are given in the Contract Data) to arrange the delivery of any securities, bonds, guarantees, proof of insurance and any other documentation to be provided in terms of the *conditions of contract* identified in the Contract Data at, or just after, the date this agreement comes into effect. Failure to fulfil any of these obligations in accordance with those terms shall constitute a repudiation of this agreement.

Notwithstanding anything contained herein, this agreement comes into effect on the date when the tenderer receives one fully completed original copy of this document, including the Schedule of Deviations (if any).



Unless the tenderer (now *Contractor*) within five working days of the date of such receipt notifies the Employer in writing of any reason why he cannot accept the contents of this agreement, this agreement shall constitute a binding contract between the Parties.

Signature(s)

Name(s)

Capacity

**for the
Employer**

Transnet SOC Ltd

Name &
signature of
witness

*(Insert name and address of
organisation)*

Date



Schedule of Deviations

Note:

1. To be completed by the Employer prior to award of contract. This part of the Offer & Acceptance would not be required if the contract has been developed by negotiation between the Parties and is not the result of a process of competitive tendering.
2. The extent of deviations from the tender documents issued by the Employer prior to the tender closing date is limited to those permitted in terms of the Conditions of Tender.
3. A tenderer’s covering letter must not be included in the final contract document. Should any matter in such letter, which constitutes a deviation as aforesaid be the subject of agreement reached during the process of Offer and Acceptance, the outcome of such agreement shall be recorded here and the final draft of the contract documents shall be revised to incorporate the effect of it.

No.	Subject	Details
1		
2		
3		
4		
5		

By the duly authorised representatives signing this Schedule of Deviations below, the Employer and the tenderer agree to and accept this Schedule of Deviations as the only deviations from and amendments to the documents listed in the Tender Data and any addenda thereto listed in the Tender Schedules, as well as any confirmation, clarification or changes to the terms of the Offer agreed by the tenderer and the Employer during this process of Offer and Acceptance.

It is expressly agreed that no other matter whether in writing, oral communication or implied during the period between the issue of the tender documents and the receipt by the tenderer of a completed signed copy of this Form shall have any meaning or effect in the contract between the parties arising from this Agreement.

	For the tenderer:	For the Employer
Signature	_____	_____
Name	_____	_____
Capacity	_____	_____
On behalf of	<i>(Insert name and address of organisation)</i>	Transnet SOC Ltd
Name & signature of witness	_____	_____
Date	_____	_____

C1.2 Contract Data

Part one - Data provided by the *Employer*

Clause	Statement	Data
1	General	
	The <i>conditions of contract</i> are the core clauses and the clauses for main Option:	
	dispute resolution Option	A: Priced contract with price list
	and secondary Options	W1: Dispute resolution procedure
		X2 Changes in the law
		X17: Low service damages
		X18: Limitation of liability
		Z: <i>Additional conditions of contract</i>
	of the NEC3 Term Service Contract (June 2005) (and amended June 2006 and April 2013)	
10.1	The <i>Employer</i> is:	Transnet Freight Rail, A Division of Transnet SOC Ltd
	Address	Registered address: Transnet Corporate Centre 138 Eloff Street Braamfontein JOHANNESBURG 2000
	Tel No.	(011) 308 3000
	Fax No.	
	Having elected its Contractual Address for the purposes of this contract as:	Transnet Freight Rail Supply Chain Services- Pretoria Nzasm Building Corner Minaar and Paul Kruger Street Pretoria 0001
	Tel No.	012 315 2059
10.1	The <i>Service Manager</i> is (name):	Arinao Nembilwi



Address	Cnr Minnaar and Paul Kruger Street Pretoria 0001
Tel	
e-mail	Arinao.nembilwi@transnet.net
11.2(2)	The Affected Property is Transnet Freight Rail Buildings
11.2(13)	RENOVATION OF MAIN GENERAL BUILDINGS (GB CIBD) AT VARIOUS TRANSNET FREIGHT RAIL DEPOTS ACROSS EASTERN REGION FOR A PERIOD OF 06 MONTHS. (KOEDOESPOORT)
11.2(14)	<p>The following matters will be included in the Risk Register</p> <p>Working at height-Falling Moving Trains- collision and trapping Falling objects-Head and foot injuries. Improperly operated grinding machine and drills- Body injuries. Inhalation of fumes from grinding machine and chemical(paints) fume -respiratory diseases Falling of equipment-1. Body injuries 2. Damage to property Dust- Respiratory diseases Noise- Hearing loss Dangerous insects and wasp-Dangerous insects and wasp bite. Wild animals-body injuries High Voltage Overhead cables 1. Electrocution 2. Electric shock Improperly operated drilling machines- Body injuries Trip and fall- Body injuries Using defective/wrong hand tools- Hands and body injuries.</p>
11.2(15)	Part 3: The Scope of Services
12.2	the Republic of South Africa subject to the jurisdiction of the Courts of South Africa.
13.1	English
13.3	2 weeks
2	The Contractor's main responsibilities (If the optional statement for this section is not used, no data will be required for this section)
21.1	2 weeks of the Contract Date
3	Time

30.1	The <i>starting date</i> is.	
30.1	The <i>service period</i> is	06 Months
4	Testing and defects	52 (fifty-two) weeks after Completion of the whole of the service
5	Payment	
50.1	The <i>assessment interval</i> is	25th (twenty-fifth) day of each successive month.
51.1	The <i>currency of this contract</i> is the	South African Rand.
51.2	The period within which payments are made is	Payment will be effected on or before the last day of the month following the month during which a valid Tax Invoice and Statement were received.
51.4	The <i>interest rate</i> is	The prime lending rate of the Standard Bank South Africa.
6	Compensation events	determined by a suitable weather station most conveniently located in the Affected area
60.1 (15)	A weather measurement is	The weather data are the records of past weather measurements for each calendar month which were recorded at: (Koedoespoort)
60.1 (15)	The <i>weather data</i> is	
7	Use of Equipment Plant and Materials	No additional data is required for this section of the <i>conditions of contract</i>.
8	Risks and insurance	
84.1	The minimum limit of indemnity for insurance in respect of loss and damage to property (except goods, plant and materials and equipment) and liability for bodily injury or death of a person (not an employee of the <i>Service Provide</i>) caused by activity in connection with this contract for any one event is:	Whatever <i>Contractor</i> deems necessary as the <i>Employer</i> is not carrying this indemnity.
84.1	The minimum limit of indemnity for insurance in respect of death of or bodily injury to employees of the <i>Contractor</i> arising out of and in the course of their employment in connection with this contract for any one event is:	As prescribed by the Compensation for Occupational Injuries and Diseases Act No. 130 of 1993 and the <i>Contractor's</i> common law liability for people falling outside the scope of the Act.
84.1	The <i>Contractor</i> liability to the <i>Employer</i> for indirect or consequential loss including loss of profit, revenue and goodwill, is limited to:	The total of the prices.

84.1	For any one event, the <i>Contractor</i> liability to the <i>Employer</i> for loss of or damage to the <i>Employers</i> property is limited to:	The total of the prices.
84.1	The <i>Contractor</i> total liability to the <i>Employer</i> for all matters arising under or in connection with this contract, other than the excluded matters, is limited to:	The total of the prices.
9	Termination	There is no Contract Data required for this section of the <i>conditions of contract</i>.
10	Data for main Option clause	
A	Priced contract with price list	
20.5	The <i>Contractor</i> prepares forecasts of the final total of the Prices for the whole of the <i>service</i> at intervals no longer than	4 (four) weeks.
11	Data for Option W1	
W1.1	The <i>Adjudicator</i> is (Name)	Both parties will agree as and when a dispute arises. If the parties cannot reach an agreement on the <i>Adjudicator</i>, the chairman of the Association of Arbitrators will appoint an <i>Adjudicator</i>.
W1.2(3)	The <i>Adjudicator nominating body</i> is: If no <i>Adjudicator nominating body</i> is entered, it is	The Association of Arbitrators (Southern Africa)
W1.4(2)	The <i>tribunal</i> is:	Arbitration
W1.4(5)	The <i>arbitration procedure</i> is The place where arbitration is to be held is The person or organisation who will choose an arbitrator - if the Parties cannot agree a choice or - if the arbitration procedure does not state who selects an arbitrator, is	The Rules for the Conduct of Arbitrations of the Association of Arbitrators (Southern Africa) Johannesburg The Chairman of the Association of Arbitrators (Southern Africa)
12	Data for secondary Option clauses	

X2	Changes in the law	There is no reference to Contract Data in this Option and terms in italics are identified elsewhere in this Contract Data.
X17	Low service damages Delay on Completion of the <i>works</i> per Task order	R 12,000.00 per day for any extra day that the supplier spend on site in completing any outstanding activity
X18	Limitation of liability	
X18.1	The <i>Contractor's</i> liability to the <i>Employer</i> for indirect or consequential loss is limited to	Nil.
X18.2	For any one event, the <i>Contractor's</i> liability to the <i>Employer</i> for loss of or damage to the <i>Employer's</i> property is limited to	The deductible of the relevant insurance policy
X18.3	The <i>Contractor's</i> liability for Defects due to his design of an item of Equipment is limited to	The cost of correcting the defect.
X18.4	The <i>Contractor's</i> total liability to the <i>Employer</i> , for all matters arising under or in connection with this contract, other than the excluded matters, is limited to	Total of the Prices.
X18.5	The <i>end of liability date</i> is	1 years after the end of the <i>service period</i>.
Z	<i>Additional conditions of contract</i>	
Z.1	<i>Obligations in respect of Subcontracting</i>	Not Applicable

Z.2 Local Production and Content Obligations (If applicable)

Z.2.1 *In terms of Local Production and Content (SBD 6.2), Annexure A and Annexure C of the Returnable Schedule T2.2-03 Eligibility Criteria Schedule: Declaration Certificate of Local Production and Content, the Contractor has undertaken to fulfil its obligations of the Local Production and Content for the following designated sectors: **designated various sectors:***

Z2.2 The *Contractor* is required to note that the *Employer*, the Department of Trade and Industry [DTI] and/or the body appointed by the DTI as the verification authority for local content may conduct compliance audits with regard to the Local Production and Content requirements as prescribed in Regulation 8 of the Preferential Procurement Regulations, 2017 issued in terms of the Preferential Procurement Policy Framework Act no. 5 of 2000.

Z2.3 The *Contractor* is required to continuously update Declarations C, D and E of the Local Production and Content Declaration commitments with the actual local content values for the duration of the contract.

The *Contractor* shall report to the *Employer* on a monthly basis during the term of the Contract, the amounts spend on Local Production and Content for the designated sectors for the duration of the contract.

Z2.4 The *Contractor* must refer to Schedule A attached to the Returnable Schedule T2.2-3 Eligibility Criteria Schedule: Declaration Certificate of Local Production and Content concerning non-compliance penalties applicable to Local Production and Content.

Z2.5 Breach of Local Production and Content commitments provides the *Employer* cause to terminate the contract.

Z3 Additional clause relating to Performance Bonds and/or Guarantees *Not Applicable*

Z4 Additional clauses relating to Joint Venture

Insert the additional core clause 27.5

27.5. In the instance that the Contractor is a joint venture, the Contractor shall provide the Employer with a certified copy of its signed joint venture agreement, and in the instance that the joint venture is an 'Incorporated Joint Venture,' the Memorandum of Incorporation, within 4 (four) weeks of the Contract Date.

The Joint Venture agreement shall contain but not be limited to the following:

- A brief description of the Contract and the Deliverables;
- The name, physical address, communications addresses and domicilium citandi et executandi of each of the constituents and of the Joint Venture;
- The constituent's interests;
- A schedule of the insurance policies, sureties, indemnities and guarantees which must be taken out by the Joint Venture and by the individual constituents;
- Details of an internal dispute resolution procedure;
- Written confirmation by all of the constituents:
 - i. of their joint and several liabilities to the *Employer* to Provide the Works;
 - ii. identification of the lead partner in the joint venture confirming the authority of the lead partner to bind the joint venture through the *Contractor's* representative;
 - iii. Identification of the roles and responsibilities of the constituents to provide the Works.
 - Financial requirements for the Joint Venture:
 - iv. the working capital requirements for the Joint Venture and the extent to which and manner whereby this will be provided and/or guaranteed by the constituents from time to time;
 - v. the names of the auditors and others, if any, who will provide auditing and accounting services to the Joint Venture.



Z4.2	Insert additional core clause 27.6
	27.6. The <i>Contractor</i> shall not alter its composition or legal status of the Joint Venture without the prior approval of the <i>Employer</i> .

Z5 Obligations in respect of Termination

Z5.1	<p>The following will be included under core clause 91.1:</p> <p>In the second main bullet, after the word 'partnership' add 'joint venture whether incorporated or otherwise (including any constituent of the joint venture)'; and</p> <p>Under the second main bullet, insert the following additional bullets after the last sub-bullet:</p> <ul style="list-style-type: none"> • commenced business rescue proceedings (R22) • repudiated this Contract (R23)
------	--

Z5.2	Termination Table	<p>The following will be included under core clause 90.2 Termination Table as follows:</p> <p>Amend "A reason other than R1 – R21" to "A reason other than R1 – R23"</p>
------	-------------------	--

Z5.3	Amend "R1 – R15 or R18" to "R1 – R15, R18, R22 or R23."
------	---

Z6 Right Reserved by Transnet to Conduct Vetting through SSA

Transnet reserves the right to conduct vetting through State Security Agency (SSA) for security clearances of any Contractor who has access to National Key Points for the following without limitations:

1. Confidential – this clearance is based on any information, which may be used by malicious, opposing or hostile elements to harm the objectives and functions of an organ of state.

Secret – clearance is based on any information which may be used by malicious, opposing or hostile elements to disrupt the objectives and functions of an organ of state.

Top Secret – this clearance is based on information which may be used by malicious, opposing or hostile elements to neutralise the objectives and functions of an organ of state.

**Z7 Additional clause relating to Collusion
in the Construction Industry**

Z7.1 The contract award is made without prejudice to any rights Transnet may have to take appropriate action later with regard to any declared bid rigging including blacklisting.

Z8 Protection of Personal Information Act

Z8.1 The *Employer* and the *Contractor* are required to process information obtained for the duration of the Agreement in a manner that is aligned to the Protection of Personal Information Act

C1.2 Contract Data

Part two - Data provided by the *Contractor*

The tendering contractor is advised to read both the NEC3 Term Service Contract (June 2005) and the relevant parts of its Guidance Notes (TSC3-GN) in order to understand the implications of this Data which the tenderer is required to complete.

Completion of the data in full, according to Options chosen, is essential to create a complete contract.

Clause	Statement	Data
10.1	The <i>Contractor</i> is (Name): Address Tel No. Fax No.	
11.2(8)	The <i>direct fee percentage</i> is%
	The <i>subcontracted fee percentage</i> is%
11.2(14)	The following matters will be included in the Risk Register
24.1	The key persons are:	
	1 Name:
	Job:
	Responsibilities:
	Qualifications:
	Experience:
	2 Name:
	Job
	Responsibilities:
	Qualifications:
	Experience:
	
		CV's (and further key person's data including CVs) are in
A	Priced contract with price list	
11.2(12)	The <i>price list</i> is in
11.2(19)	The tendered total of the Prices is	R.....



PART C2: PRICING DATA

Document reference	Title	No of pages
C2.1	Pricing instructions: Option A	
C2.2	Price List	



C2.1 Pricing instructions: Option A

1.1 The *conditions of contract*

1.2 How the contract prices work and assesses it for progress payments

Clause 11 in NEC3 Term Services Contract (TSC), June 2005 (with amendments June 2006 and April 2013) Option A states:

**Identified 11
and defined
terms**

- 11.2 (17) The Price for Services Provided to Date is the total of
- the Price for each lump sum item in the Price List which the *Contractor* has completed and
 - where a quantity is stated for an item in the Price List, an amount calculated by multiplying the quantity which the *Contractor* has completed by the rate.

(19) The Prices are the amounts stated in the Price column of the Price List, where a quantity is stated for an item in the Price List, the Price is calculated by multiplying the quantity by the rate.

1.3 Measurement and Payment

- 1.3.1 The Price List provides the basis of all valuations of the Price for Services Provided to Date, payments in multiple currencies and general progress monitoring.
- 1.3.2 The amount due at each assessment date is based on activities and/or milestones completed as indicated on the Price List.
- 1.3.3 The Price List work breakdown structure provided by the *Contractor* is based on the activity/milestone provided by the Employer. The activities listed by the *Employer* are the minimum activities acceptable and identify the specific activities which are required to achieve Completion. **The Price List work breakdown structure is compiled to the satisfaction of the *Employer* with any additions and/or amendments deemed necessary.**
- 1.3.4 The *Contractor's* detailed Price List summates back to the activity/milestone provided by the *Employer* and is sufficient detail to monitor completion of activities related to the operations on the Accepted Plan in order that payment of completed activities may be assessed.
- 1.3.5 The Prices are obtained from the Price List. The Prices includes for all direct and indirect costs, overheads, profits, risks, liabilities, obligations, etc. relative to the contract.



C2.2 Price List

Section C Koedoespoort and Pretoria West

Item no.	DESCRIPTION: Renovate 02YB593P PRETORIA WEST ABLUTION	Unit	Quantity	Rate	Price
A	A. PRELIMINARY AND GENERALS				
1	Contractual requirement	Sum.			
2	Facilities required by contractor	Sum.			
3	General responsibilities and other fixed-charge obligations	Sum.			
4	Removal of site establishment	Sum.			
	B BUILDING RENOVATIONS: 02YB593P ABLUTION				
1	Demolish wall and floor tiles complete and make wall and floor good.	Sum.	1.		
2	Supply and replace all window stays, peg stays and handles with new heavy duty brass ones	No.	70		
3	Demolish existing toilet pan and cistern	No.	4		
4	Supply and replace broken glass windows with 3mm clear window panes	M ² .	10		
5	Supply and replace broken glass windows with 3mm obscured window panes	M ² .	10		
6	Supply and Fit new fabric vertical blinds colour – Plain Fawn with aluminium top rail. (0.974wide*0.881drop) 18 windows.	No.	24		
7	Demolish and Remove porcelain wash hand basin 560mm wide	Ea.	6		
8	Fit indicator bolt and indicator signs(male and female)to toilet door	No.	11		
9	Remove and replace mortise lock 3 lever	No.	10		



	union lock				
10	Supply and fit three stainless steel roll lockable toilet paper dispenser attached to wall in toilet.	No.	4		
11	Remove floor covering, Chip floor apply pro grip to floor fit new porcelain floor tiles 300x300 code 33751165EZC139 complete with dove grey grouting and 100mm tile skirting and protection steel/aluminium cover at doors and steps and plastic one on skirting in bathroom, passage, storeroom and kitchen	M ² .	290		
12	Supply and install mosaic tiles in showers	M ²	15		
13	Paint ceiling two coats DURA 65 WHITE,	M ²	300		
14	Remove, replace and install ceiling 3mm thick complete with cover strips and matching cornice and make and install a trap door	M ²	300		
15	Repair and prepare by removing old paint flakes paint all window frames with Two coats universal undercoat and two coats Pearl glo Lockness code -3L1-5. Window size 0.975 wide * 0.881 drop	No.	29		
16	Paint door frames and doors Sand and apply two coats Wood guard timber varnish double doors	No.	12		
17	Paint door frames and doors Sand and apply two coats Wood guard timber varnish single door	No.	12		
18	Demolish sink complete, re-plumb water supply for new sink with copper pipe under plaster and tiles and discontinue pipes not to be used anymore(make good wall) water supply pipes to be from the outside	No.	1		
19	Supply and fit 450 x 600mm silver mirror, mounted flush with tiles using double sided tape above wash hand basins at eye level.	No.	4		
20	Make and install sink with double deck cabinet . Cherry wood melamine with double drop- in -sink and grey granite top and back splash 100mm (wall sides). Build half brick wall at front, back and sides. Provide tile skirting at front to match existing floor tiles. Cabinet to rest on half brick wall. Replace mixer complete with cobra heavy duty, connect to drain. Size of cabinet 2m long. Tile 2 lines above granite with	Sum.	1		



21	Repair wall, scrub off lose paint and fill cracks with rhino blaster, Paint internal walls two universal undercoat and coats Wash N Wear Silk, Barely Beige code - 3H1-1	M ²	600		
22	Remove and replace wall tiles in bathroom and kitchen with 200*200 white glazed wall tiles from floor to ceiling, replace cornice.	M ²	210		
23	Supply and install porcelain flat back urinal complete with cobra push button, anti-vac bottle trap, connect to sewer.	No.	2.		
24	Supply and make shower p-traps-brass deep seal with chrome grid- and shower floor, with individual waste pipe and connect to the sewer.	No.	8.		
25	Supply and install shower rose, chrome swivel with swan neck extension.	No.	8		
26	Supply, Make and install showers with hot and cold water supply, complete with star type under tile stop cocks for hot and cold water supply and all accessories with class 2, 15mm copper pipes chase pipe into walls	No.	8		
27	Supply and install Vaal Potteries close couple toilet pan and cistern with heavy-duty toilet seat and flap Econo B2. Supply each with ball-o-stop.	No.	6		
28	Supply and install porcelain wash hand basin 560mm wide complete with heavy duty pillar taps, anti-vac bottle trap and connect to drain and water supply. Supply each with ball-o-stop, connect to water and drain	No.	6		
29	Supply and install F,L&B single Door complete	No	8		
30	Supply and fit in flush back hardboard single door complete	No	7		
31	Supply and install chrome soup dish	No	8		
32	Remove all galvanised pipes, supply and install copper pipes for both cold and hot water supplies to basins, kitchens, shows, toilets etc, including main supply on the outside NB-Complete re-plumbing	Sum	1		
33	Supply, install and connect new sewer line 110 mm Φ to existing line. Include all cutting in existing sewer, pan connector, soil and vent, air vent 110 mm Φ , bends,	M.	50		



	junctions etc. to comply with SABS 10400.				
34	Supply, install and Provide water point 15 mm Φ (Copper) to inside of the building include all fittings and pipe include accessories i.e. stopcocks etc.	Sum.	1		
35	Supply and fit 50mm PVC waste drainage pipes complete with all fittings and consumables	M.	15		
36	Chase walls for all new water pipes, plaster and make walls good, prepare for painting	Sum	1.		
37	Supply cast 25mpa cement stone and sand (concrete) shower floors	M3	2		
38	Supply and install/plaster 15mm in 1:4 cement sand plaster build walls and smoothly finish preparing for paint	M2			
39	Supply and build half brick wall with cement bricks and cement sand mortar with DPC and brick force at every 3rs course	M ²	3		
40	Supply and install Aluminium Pivot obscure safety glass shower doors	Sum	8		
C	C EXTERIOR OF THE BUILDING				
1	Supply and install NU-TECH barge boards and fascia boards	M	60		
2	Paint door frames, security doors and doors, one coat white universal under coat and two coats Pearl glo Lockness code - 3L1-5	No.	4		
3	Replace loose roof screws with 90mm posy drive screws with 26mm bonded washers	No.	50		
4	Prepare by scrubbing off all loose flakes, clean and Paint all exposed water and waste pipes- one coat white universal under coat and two coats Pearl glo Lockness code - 3L1-5	Sum.	1		
5	Supply and install white Chromadecontinuous gutters 125x80mm complete with 8matching down pipes	M	72		
6	Seal roof for leaks, remove loose flakes, patch, and sand off and prepare Paint G.I roof primer NS4 and two coats roof guard, cottage white. (roof leaks to be guided by ceiling stains)	M2	180		
7	Replace Brocken and cracked putty in windows and neatly finish new putty and paint	Sum.	1		



8	Replace all broken window panes , window stays, window handle and window peg stay	Sum.	1		
9	Supply and install assert number. Chromadek plate 300mm longx60mm high. Arial black 40mm high. Royal blue vinyl	No.	1.		
10	Supply and install plastic gully grid	No.	6		
11	Prepare by removing all loose flakes, repair any wall cracks, holes or broken plaster and Paint external walls 1 coat universal under coat and two coats Weather Guard Barely Beige code - 3H1-1 paint door frames and doors and windows plus burglar bars one coat white Du Lux universal under coat and two coats Dulux Pearlgl Lockness code - 3L1-5.				
			02YB593 P	Total.	R

Item no.	Description: 02AW378P KOEDOESPOORT INFRASTRUCTURE ANDMIN BUILDING REPAIRS AND MAINTENANCE	Unit	Quantity	Rate	Price
A	PRELIMINERY AND GENERALS				
1.	Contractual requirement	Item			
2.	Facilities required by contractor	Item			
3.	General responsibilities and other fixed-charge obligations	Item			
4.	Removal of site establishment	Item			
B	BUILDING RENOVATIONS				
5.	Demolish floor tiles, screed and slab complete in the passage.	M ³	10.5.		
6.	Demolish and remove earth filling in the passage	M ³	50		
7.	Supply and install G5 material , moist, lay	M ³	50		

	and compact in 150mm layers to a Modd Ashto of 95%				
8.	Supply and install REF 193 Mesh wire	M ²	166		
9.	Supply and install 25 MPA concrete slab with 19mm concrete stone, compact with a poker vibrator and cure- concrete cube samples and results to be provided.	M ³	10.5.		
10.	Supply and replace all window stays, peg stays and handles with new heavy duty brass ones	No.	72		
11.	Supply and Fit new fabric vertical blinds colour – Plain Fawn with aluminium top rail. (1000wide*1500mmdrop) 27 windows	No.	27		
12.	Supply and Fit new fabric vertical blinds colour – Plain Fawn with aluminium top rail. (1500wide*1500mmdrop) 4 windows.	No.	4		
13.	Supply and Fit new fabric vertical blinds colour – Plain Fawn with aluminium top rail. (2000wide*1500mmdrop) 34 windows.	No.	34		
14.	Repair and prepare by removing old paint flakes paint all window burglars with Two coats universal undercoat and two coats Pearl glo Lockness code -3L1-5. Window size (1000wide*1500mmdrop) 27 windows	No.	27		
15.	Repair and prepare by removing old paint flakes paint all window burglars with Two coats universal undercoat and two coats Pearl glo Lockness code -3L1-5. Window size (1500wide*1500mmdrop) 4 windows.	No.	4		
16.	Repair and prepare by removing old paint flakes paint all window burglars with Two coats universal undercoat and two coats Pearl glo Lockness code -3L1-5. Window size (2000wide*1500mmdrop) 34 windows.	No.	34		
17.	Repair and prepare by removing old paint flakes paint all window burglars with Two coats universal undercoat and two coats Pearl glo Lockness code -3L1-5. Window size (1900 wide * 600mm drop) 7 windows	No.	7		
18.	Repair and prepare by removing old paint flakes paint all window seals with Two coats wall guard universal undercoat and two coats black	Item.	1		

19.	Repair and prepare by removing old paint flakes and paint all single door burglars with Two coats universal undercoat and two coats Pearl glo Lockness code -3L1-5.	No.	3		
20.	Repair and prepare by removing old paint flakes and paint security burglar with Two coats universal undercoat and two coats Pearl glo Lockness code -3L1-5. (2200 wide * 2400mm drop)	No.	1		
21.	Repair and prepare by removing old paint flakes and paint security burglar with Two coats universal undercoat and two coats Pearl glo Lockness code -3L1-5. (3500 wide * 2400mm drop)	No.	1		
22.	Repair and prepare by removing old paint flakes and paint security burglar with Two coats universal undercoat and two coats Pearl glo Lockness code -3L1-5. (4900 wide * 2400mm drop)	No.	1		
23.	Repair and prepare by removing old paint flakes and paint security burglar with Two coats universal undercoat and two coats Pearl glo Lockness code -3L1-5. (3800 wide * 2400mm drop)	No.	1		
24.	Fit indicator bolt and indicator signs(male, female and PWD)to toilet door	No.	6		
25.	Supply and fit stainless steel roll lockable toilet paper dispenser attached to wall in toilet.	No.	8		
26.	Remove floor covering, Chip floor apply pro grip to floor fit new porcelain floor tiles beige 600x600complete with dove grey grouting and 100mm tile skirting and protection steel/aluminium cover at doors and steps and plastic one on skirting in bathroom, passage and kitchen	M ² .	1055		
27.	Remove existing ceiling complete, Supply and install Don Shield SUSPENDED ceiling complete with all Fittings, use flat steel strips as hangers	M ²	1055		
28.	Repair and prepare by removing old paint flakes paint all window frames with Two coats universal undercoat and two coats Pearl glo Lockness code -3L1-5. Window size 1000 wide * 1500mm drop	No.	27		
29.	Repair and prepare by removing old paint flakes paint all window frames with Two		4		

	coats universal undercoat and two coats Pearl glo Lockness code -3L1-5. Window size 1500 wide * 1500mm drop	No.			
30.	Repair and prepare by removing old paint flakes paint all window frames with Two coats universal undercoat and two coats Pearl glo Lockness code -3L1-5. Window size 2000 wide * 1500mm drop	No.	34		
31.	Repair and prepare by removing old paint flakes paint all window frames with Two coats universal undercoat and two coats Pearl glo Lockness code -3L1-5. Window size 1900 wide * 600mm drop	No.	7		
32.	Sand single wooden door frame and apply two coats wood guard timber varnish	No.	3		
33.	Repair and prepare by removing old paint flakes paint all single steel door frames with Two coats universal undercoat and two coats Pearl glo Lockness code -3L1-5.	No	38		
34.	Repair and prepare by removing old paint flakes paint all steel double door frames with Two coats universal undercoat and two coats Pearl glo Lockness code -3L1-5.	No	2		
35.	Sand wooden door and apply two coats wood guard timber varnish	No.	34		
36.	Repair and prepare by removing old paint flakes paint combined steel window frame and double door with Two coats universal undercoat and two coats Pearl glo Lockness code -3L1-5. (3800 wide * 2400mm drop)	No.	3		
37.	Repair and prepare by removing old paint flakes paint wooden doors with Two coats universal undercoat and two coats Pearl glo Lockness code -3L1-5.	No	10		
38.	Remove wooden door and frame. Supply and install heavy duty steel door frame and meranti door FL&B and apply two coats Wood guard timber varnish. Paint steel door frame with Two coats universal undercoat and two coats Pearl glo Lockness code -3L1-5.	Item	1		
39.	Remove wooden hallow door. Supply and install new wooden hallow door and apply two coats Wood guard timber varnish	No	1		
40.	Sand and apply two coats Wood guard	M ²	78		



	timber varnish on cupboard				
41.	Supply and fit 450 x 600mm silver mirror, mounted flush with tiles using double sided tape above wash hand basins at eye level.	No.	8		
42.	Demolish cabinet with sink. Make and install new sink with cabinet and hydroboil. Cherry wood melamine with double drop- in -sink and grey granite top and back splash 100mm (wall sides). Build half brick wall at front, back and sides. Provide tile skirting at front to match existing floor tiles. Cabinet to rest on half brick wall. Replace mixer complete with cobra heavy duty, connect to drain. Size of cabinet 3m long. Tile 3 lines above granite with 300x600mm white glazed wall tiles.	Sum	1		
43.	Demolish cabinet with sink and wall tiles. Make and install new sink with cabinet and hydroboil. Cherry wood melamine with double drop- in -sink and grey granite top and back splash 100mm (wall sides). Build half brick wall at front, back and sides. Provide tile skirting at front to match existing floor tiles. Cabinet to rest on half brick wall. Replace mixer complete with cobra heavy duty, connect to drain. Size of cabinet 3,8m long on both sides. Sink is to be installed on one side. Tile 4 lines above granite with 300x600mm porcelain wall tiles and install steel protection edge strip at all edges.	Item	1		
44.	Wash walls with sugar soap and prepare for paint and paint two universal undercoat and two coats Wash N Wear Silk, Barely Beige code - 3H1-1. Item includes paint all outside window lintels	M ²	1680		
45.	Remove and replace wall tiles in bathrooms with 300x600mm porcelain wall tiles and install steel protection edge strip at all edges. From floor to ceiling.	M ²	240		
46.	Remove urinal complete and supply and install porcelain flat back urinal complete with cobra push button, anti-vac bottle trap, connect to sewer.	No.	4.		
47.	Supply and make shower p-traps-brass deep seal with chrome grid- and shower floor, with individual waste pipe and connect to the sewer.	No.	1.		
48.	Supply and install shower rose, chrome	No.	1		



	swivel with swan neck extension.				
49.	Supply, Make and install showers with hot and cold water supply, complete with star type under tile stop cocks for hot and cold water supply and all accessories with class 2, 15mm copper pipes chase pipe into walls	No.	1.		
50.	Remove water closet complete and supply and install new Vaal Potteries close couple toilet pan and cistern with heavy-duty toilet seat and flap Econo B2. Supply each with ball-o-stop and connect to drain. Make way for soil pipe through wall and make the wall good.	No.	7		
51.	Remove PWD water closet complete and supply and install new PWD Vaal Potteries close couple toilet pan and cistern complete with rails and heavy-duty toilet seat and flap Econo B2. Supply with ball-o-stop and connect to drain.	No.	1		
52.	Supply and install porcelain wash hand basin 560mm wide complete with heavy duty pillar taps, anti-vac bottle trap and connect to drain and water supply. Supply each with ball-o-stop, connect to water and drain	No.	9		
53.	Wash and clean face brick walls with chemical detergent and high-pressure washer	M ² .	3265		
54.	Wash and clean passage walls tiles with chemical detergent and high-pressure washer	M ²	264		
55.	Supply and install chrome soup dish	No	3		
56.	Replace gutters with new chromadeck 125 x 80mm	M	194		
57.	Fit white chromadeck down pipes complete with offset 100x75mm	No	17		
58.	Fit new Nu-tec fascia board 250mm	M	80		
59.	Prepare all exposed roof timber by scrapping off all lose paint, paint 2 coats enamel white	Item	1		
60.	Repair roof by removing flakes, patch and seal with flash harry, Paint roof one coat roof primer and 2 coats white roof guard paint	M ²	1530		
61.	Allow for replacement of broken windows	M ²	5		



62.	Replace corrugated ridge valleys	M	20		
63.	Replace corrugated ridge cap	M	104		
64.	Trim all tree branches hanging over the roof around the building	Item	1		

	TOTAL SECTION C	
	TOTAL	R
	VAT @ 15 %	R
	TOTAL SECTION C	R

C3: Scope of Work

C3.1 Service Information

1. Description of the *service*

The provision for repair and maintenance to real estate eastern region building maintenance projects 2020-2021

This shall include:

- Demolishing and Cut-off.
- Superstructure.
- Windows Schedule.
- Carpentry work.
- Plumbing work.
- Sanitary ware and Fittings
- Plastering.
- Ceiling and insulation.
- Wall and flooring.
- Painting.
- Kitchen and Cupboards.

1.0 SCOPE OF SERVICE

1.1 This specification calls for **The provision for repair and maintenance to 02 AJ 118 P, 02AJ162P and 02 AJ 160 P, 02 AJ 158 P, Komatipoort ops** and shall in all respects comply with all regulations.

2.0 GENERAL SCHEDULE OF SERVICE

2.1 Civil work Building 02 AJ 118 P, 02AJ162P and 02 AJ 160 P, 02 AJ 158 P,

2.1.1 Site clearance

a) clear site to remove shrubs, trees hanging over buildings and 3m around the buildings and grass 2 metres around the building

2.1.2 Demolishing and Cut-off:

- a) Demolish and remove Tiles and dump it to a local Municipality dumping site.
- b) Demolish walls, ceiling and sanitary fittings (basins,urinals,toilets)
- c) Demolish shower walls, Shower doors and showers completely and make good.

2.1.3 Carpentry work:

- a) Supply, remove and replace door locks with new 4 lever mortise door locks.
- b) Supply and fit in flush back hardboard double door complete.
- c) Supply and install Meranti FL&B wooded single doors
- d) Supply and install Meranti FL&B wooded Double door
- e) Make and install sink with cabinet. Cherry wood melamine with double drop- in -

sink and grey granite top and back splash 100mm (two sides). Build half brick wall at front, back and sides. Provide tile skirting at front to match existing floor tiles. Cabinet to rest on half brick wall.

- f) Repair cracked roof seals in hips and valleys.
- g) Make and install 2M double deck cabinet. Cherry wood melamine with double drop-in -sink and grey granite top and back splash 100mm (two sides). Build half brick wall at front, back and sides. Provide tile skirting at front to match existing floor tiles. Cabinet to rest on half brick wall.
- h) Supply and manufacture roof trusses with 152*38mm SSAP black cross timber
- i) Supply and install 75*50 mm SSAP black cross Purlins
- j) Supply and install 0.5mm thickness white Chromadek 171.5 profile IBR roof sheets, continuous on trusses on purlins as per Specification, complete with all accessories, and a rolled ridge cap

2.1.4 **Plumbing work:**

- a) Drill holes 15-25mm Φ through 230 mm and 130mm brick wall respectively for water pipes and make good.
- b) Supply and fit 40mm PVC waist drainage pipes.
- c) Supply, install and Provide water point 15 mm Φ (Copper) to inside of the building include all fittings and pipe but exclude accessories i.e. stopcocks etc.
- d) Supply, install and connect new sewer line 110 mm Φ to existing line. Include all cutting in existing sewer, pan connector, soil and vent, air vent 110 mm Φ , bends, junctions etc. to comply with SABS 10400.
- e) Supply and install porcelain wash hand basin 560mm wide complete with heavy duty pillar taps, anti-vac bottle trap and connect to drain and water supply. Supply each with ball-o-stop, connect to water and drain
- f) Supply and install close couple toilet pan and cistern with heavy-duty toilet seat and flap Econo B2. Supply each with cobra ball-o-stop.
- g) Supply, Make and install showers with hot and cold water supply, complete with cobra star type under tile stop cocks for hot and cold water supply and all accessories with class 2, 15mm copper pipes
- h) Supply and install shower rose-, chrome swivel with swan neck extension.
- i) Supply and make shower p-traps-brass deep seal with chrome grid- and shower floor, with individual waste pipe and connect to the sewer.
- j) Supply and install porcelain flat back urinal complete with push button, anti-vac bottle trap, connect to sewer.

2.1.5 **Ceilings and insulation:**

- a) Supply and install ceiling 4mm thick complete with cover strips and matching cornice and make and install a trap door.
- b) Supply and install Don Shield SUSPENDED ceiling complete , use flat steel strips as hangers

2.1.6 **Wall and Floor Covering :**

- a) Supply and install tiles by Applying pro grip to floor fit new porcelain floor tiles 300x300 code: 33751165EZC139 complete with dove grey grouting and 75mm tile skirting and Aluminium tile edge protector at doors and steps.
- b) Supply and fit 300x600mm white glazed wall tiles from floor to ceiling, use grey grouting ,
- c) Supply and install i mosaic tiles.
- d) Remove existing tiles, supply and install non-slippery 600*600 porcelain tiles beige

2.1.7 **Painting:**

- a) Supply pint, repair and Paint int. wall with (PVA) –Two coats Dura 65 white. Two coats coats (paint must be with a quality guarantee of a minimum 10 years) Wash

- N Wear Silk, Barely Beige code 3H1-1.
- b) The contractor shall Paint Flashing and Fascia boards with 2 coats Enamel Dura 65 white.
 - c) Scribe and remove loose flakes and rust, prepare Paint G.I roof 2 coats primer and two coats coats (paint must be with a quality guarantee of a minimum 10 years) roof guard, cottage white
 - d) Repair and prepare by removing old paint flakes, Paint Doors and doorframes to (Painted) Two coats universal undercoat and two coats (paint must be with a quality guarantee of a minimum 10 years) Pearl glo Lockness code -3L1-5.
 - e) Paint all exposed water and waste pipes- one coat white Du Lux (or any other make with matching colour and a guarantee of a minimum 10 years) universal under coat and two coats coats (paint must be with a quality guarantee of a minimum 10 years) Pearl glo Lockness code - 3L1-5
 - f) Repair and prepare by removing old paint flakes, Paint purlins/rafters/sprocket ends to Dulux universal white undercoat. Primer on wood/steel - Pink primer (wood) NS4 (steel). Two coats White coats (paint must be with a quality guarantee of a minimum 10 years) high gloss enamel.
 - g) Repair and prepare by removing old paint flakes paint all windows with Two coats universal undercoat and two coats coats (paint must be with a quality guarantee of a minimum 10 years) Pearl glo Lockness code -3L1-5.

2.1.8 Specialised work

- a) Supply and install chrome coat hooks
- b) Supply and replace all glass windows with 3mm clear window panes and obscured glass in rest rooms and ablution respectively
- c) Fit white Chromadek down pipes 100x75mm
- d) Supply and replace all window stays, peg stays and handles with new heavy duty brass ones
- e) Supply and install 1800mm*2100mm aluminum bronze swing double door with shatterproof tinted (30%) glass in the openings leading to the office- complete with a floor mounted quad aluminum door stopper and a frame/wall mounted aluminum door closer.
- f) Supply and fit three roll lockable stainless steel toilet paper dispenser attached to wall in toilet.
- g) Supply and fit 450 x 600mm silver mirror, mounted flush with tiles using double sided tape above wash hand basins at eye level
- h) Supply and install assert number. Chromadek plate 300mm longx60mm high. Arial black 40mm high. Royal blue vinyl
- i) Supply and Fit white Chromadek continuous gutters 125x80mm
- j) Supply and Fit new fabric vertical blinds colour – Plain Fawn with aluminum top rail. Blinds inside window recesses- **NB: a successful Contractor should reaffirm and verify the window measurements before ordering them as we will not be held responsible for incorrect blind sizes**

NB: All work must be of Good workmanship, Paintwork, Plumbing, Tiling and Carpentry.

Plants and Equipment Required.

- i. Tonne Bakkie
- ii. Scaffolding
- iii. Ladders.
- iv. Hand drill
- v. Grinder
- vi. Paint tools-brushes, scraper and trays

- vii. Plumbing tools-blow torch and spanners
- viii. Tile cutter
- ix. Safety harness
- x. Spirit level

MINIMUM CONTENTS FOR SHEQ PLAN AND PLANTS AND EQUIPMENTS

The contractors tendering for this project shall take note of the following when compiling Safety, health and environmental plan. Specification for service on, over, under or adjacent to railway lines and near high voltage equipment. (**E7/1 July 1998**) and shall have part A and B of Health and safety Plan as outlined below.

Part A: Health and safety Plan

SHE Management Structure

- i. Construction Work Supervisor (Construction Regulation 6)
- ii. Subordinate Construction Work Supervisor (Construction Regulation 6)
- iii. Construction Safety Officer (Construction Regulation 6(7)).
- iv. List of Contractors already appointed - List to be revised at least monthly.
- v. Health and Safety Representative (Section 17 of OHS Act).

SHE Organisation

- i. Health and Safety Committee.
- ii. Composition.
- iii. Frequency of Meetings.
- iv. Minutes of meeting.
- v. Legal Compliance Audits.
- vi. Audit Report.
- vii. Frequency of Audits.
- viii. Findings and Analysis.
- ix. Corrective Action.

Risk Assessment/Management

- i. Task descriptions.
- ii. Risk Identification, Analysis, Mitigating Steps, Monitoring Steps and Review Plan.
- iii. Risk Assessment (Construction Regulation 7)

Education and Training

- i. Induction training (Construction Regulation 7(9))
- ii. Site Specific Training.
- iii. Certificate of Competence.

Emergency Planning – Evacuation plan

- i. Client procedure.
- ii. Site Procedure.



Health and Safety Communications

- i. Safety/Toolbox talks.
- ii. Incident Recall.

Safe Working Procedures and Methods

- i. Method Statements.
- ii. Safe Operating Procedures.
- iii. Task/Job observations.

Personal Protective Equipment and Clothing

- i. PPE required after all other controls have been considered.
- ii. PPE proof of issue.

Project security

- i. Security risks identified.
- ii. Access control.

Part B. Environmental Management Plan

Note: TFR will obtain Environmental authorisation (EIA and EMP) and permits from the relevant authority (when necessary) prior to commencement of the project (e.g. Construction)

- i. Control of Dust.
- ii. Noise Pollution Control.
- iii. Waste management.
- iv. Environmental Incident Management (Sect 28 NEMA and Sect 20 National Water Act).
- v. Contamination of surface and underground water.
- vi. Soil Contamination.
- vii. Storm Water Drainage.
- viii. Environmental Clean-up and Rehabilitation.



2. Drawings

No Drawings Applicable

3. Specifications

- The Contractor shall comply with the current Specification for Service On, Over, Under or Adjacent to Railway Lines and near High Voltage Equipment – E7/1, if applicable, and shall take particular care of the safety of his employees on or in close proximity to a railway line during track occupations as well as under normal operational conditions.
- The Contractor's Health and Safety Programme shall be subject to agreement by the Employer's Deputy / Supervisor, who may, in consultation with the Contractor, order supplementary and/or additional safety arrangements and/or different safe working methods to ensure full compliance by the Contractor with his obligations as an employer in terms of the Act.
- In addition to compliance with clause 1.5.5 hereof, the Contractor shall report all incidents in writing to the Employer's Deputy / Supervisor. Any incident resulting in the death of or injury to any person on the service shall be reported within 24 hours of its occurrence and any other incident shall be reported within 48 hours of its occurrence.
- In addition to compliance with clause 1.5.5 hereof, the Contractor shall report all incidents in writing to the Employer's Deputy / Supervisor. Any incident resulting in the death of or injury to any person on the service shall be reported within 24 hours of its occurrence and any other incident shall be reported within 48 hours of its occurrence.
- No retention money will be retained.
- The Contractor shall supply a site diary (with triplicate pages). This book shall be used to record any unusual events during the period of the work. Any delays to the work shall also be recorded such as delays caused by poor weather conditions, delays caused by permits being cancelled etc. The appointed Employer's Deputy or Supervisor must countersign such delays. Other delays such as non-availability of equipment from 3rd party suppliers must be communicated to the Employer's Deputy or Supervisor in writing.
- The Contractor shall supply a site instruction book (with triplicate pages). This book shall be used to record any instructions to the Contractor regarding problems encountered on site – for example the quality of work or the placement of equipment. This book shall be filled in by the Employer's Deputy or Supervisor and must be countersigned by the Contractor. Both books mentioned in 1.5.10 and 1.5.11 shall be the property of Transnet Freight Rail and shall be handed over to the Employer's Deputy or Supervisor on the day of energising or handing over.
- All processes or the manufacture and assembly of the product components must be subjected to a quality assurance system.
- The Contractor will assume full responsibility for assuring that the products purchased meet the requirements of Transnet Freight Rail for function, performance, and reliability, including purchased products from 3rd part suppliers/Manufacturers.
- The Contractor shall prove to Transnet Freight Rail that his product or those supplied from 3rd party suppliers/manufacturers confirms to Transnet freight rail specifications.
- The Contractor will remain liable for contractual delivery dates irrespective of deficiencies discovered during servicehop inspections

5. REQUIREMENTS FOR THE PROGRAMME

5.1 FORMAT OF THE PROGRAM

- A program of activities in the form of a Gantt chart, preliminary one that includes all activities and duration of activities to be submitted with the service information and the detailed one that includes dates of all activities and events to be submitted prior to project commencement shall be submitted to the *Service Manager*. The *Service Manager* retains the right to alter the accepted program should circumstances on *site* necessitate such a change.

5.2 CONTRACTUAL OBLIGATIONS (A)

- 1.1 Both books mentioned in 1.5.10 and 1.5.11 shall be the property of Transnet Freight Rail and shall be handed over to the Employer's Deputy or Supervisor on the day of energising or handing over.



6. Services and other things provided by the Employer

Water, ablution and Electricity

Item	Date by which it will be provided
Water, electricity and ablution facilities. NB please note that should misuse us those services be uncovered, metering and billing will be implemented and the contractor shall carry the costs	From start to end date

7.1 The Contractor's Invoices

7.1.1 When the *Service Manager* certifies payment (see TSC Clause 50) following an assessment date, the *Contractor* complies with the *Employer's* procedure for invoice submission.

7.1.2 The invoice must correspond to the *Service Manager's* assessment of the amount due to the *Contractor* as stated in the payment certificate.

- 7.1.3 The invoice states the following:
- Invoice addressed to Transnet Limited;
 - Transnet Limited's VAT No: 4720103177;
 - Invoice number;
 - The *Contractor's* VAT Number; and
 - The Contract number [insert *relevant details*].

7.1.4 The invoice contains the supporting detail [*insert relevant details*].

7.1.5 The invoice is presented either by post or by hand delivery.

- 7.1.6 Invoices submitted by post are addressed to:
- Transnet Freight Rail
 - Real Estate Management



Transnet Freight Rail

Contract Number: SIG20030CIBD (HOAC-HO-34780)

Description of Services: Renovation of Main General Buildings (GB CIBD) at various Transnet Freight Rail Depots across Eastern Region for a period of 06 Months. (**Koedoespoort**)

- Private Bag X637
- Pretoria
- 0001
-

7.1.7 Invoices submitted by hand are presented to:

- Transnet Freight Rail
- Real Estate Management
- Rm 213, Nzasm Building, C/O Paul Kruger & Minnaar Str.
- Pretoria
- 0001
- For the attention of the Contract Administrator – **Wilma Erasmus, TFR Real Estate Management**, Eastern Region.

7.1.8 The invoice is presented as an original.



PART 4: SITE INFORMATION

Core clause 11.2(16) states

“Site Information is information which

- describes the Site and its surroundings and
- Is in the documents which the Contract Data states it is in.”

In Contract Data, reference has been made to this Part 4 of the contract for the location of Site Information.

1. Description of the Site and its surroundings

1.1. General description

1.1. **Pretoria West**-1 The works shall be performed at Transnet Freight Rail, Pretoria west Depot The site is accessible through ARTILLERY Road from Kgosi Mampuru drive Pretoria Co-ordinates :- **25.756204, 28.177399.**

1.2. **Koedoespoort**- The works shall be performed at Transnet Freight Rail, Koedoespoort Infrastructure Depot In Pretoria Silverton as Contract Data. The site is accessible through Dykor road into Trans Road behind Supa Quick Co-ordinates: **25.726262, 28286060.**

-

1.2. Existing buildings, structures, and plant & machinery on the Site

- The area is around buildings, platform, Railway lines and an existing tarred surface.

1.3. Subsoil information

- Soft natural soil.

Hidden services

- Sewer Network line.
- Water Network.
- Electrical Network.
- * Telecommunication network

1.4. Other reports and publicly available information

.

1. The sites, like most underdeveloped areas has a high unemployment rate and tends to be politically volatile if social structures are not engaged and included as part of the project.

To Whom It May Concern,

CERTIFICATE OF INSURANCE: TRANSNET (SOC) LIMITED – PRINCIPAL CONTROLLED INSURANCE

In our capacity as Insurance Brokers to the Transnet Group of Companies, we hereby certify that the undermentioned insurances are currently in place:

INSURED: Transnet (SOC) Limited

PERIOD: 1 April 2021 to 31 March 2022 (Both days inclusive)

DIVISION: Transnet Freight Rail, Transnet Engineering, Transnet Properties, Transnet Pipelines, Transnet National Ports Authority and Transnet Port Terminals

THE INSURED'S VAT NO: 4720103177

THE INSURED'S COMPANY REGISTRATION NO: 1990/000900/30

POSTAL ADDRESS (Head Office) P O Box 72501, Parkview, 2122

CONTRACT WORKS INSURANCE

Cover Provided : Contract Works - Physical loss or damage to the Property Insured which being materials, plant and other things for incorporation into the permanent works.

Insurer : Mirabilis (Santam Limited)

Policy Number : MZAR35023-CAR

The Contract Site : Any location within the Territorial Limits upon which The Insured Contract is to be executed or carried out as more fully defined in The Insured Contract documents together with so much of the surrounding area as may be required or designated for the performance of The Insured Contract.

Territorial Limits : The Republic of South Africa.

Additional Co-Insureds:

The Contractor: All Contractors undertaking work in connection with The Insured Contract including the Employer to the extent that the Employer undertakes work in connection with The Insured Contract;

Sub-Contractors: All Sub-Contractors employed by the Contractor and all other Sub-Contractors (whether nominated or otherwise) engaged in fulfilment of The Insured Contract; and to the extent required by any contract or agreement; transporters, suppliers, manufacturers, vendors, other persons, persons providing storage facilities, plant

owners and/or operators in respect of liability loss or damage arising out of The Insured Contract; project managers, architects, land surveyors, quantity surveyors, engineers and other advisors or consultants or sub-consultants appointed in the performance of the Insured Contract activities arising at the Contract Site provided always that any such person shall not be insured hereunder in respect of liability loss or damage arising out of such person's error or omission in the performance of the professional services for which he was appointed;

Provincial & Government: any Local Provincial or Government Department with which the Insured enters into any contract or agreement for the performance of The Insured Contract; all for their respective rights and interests.

Insured Contracts : All Contracts (including any undertaking awarded or commenced prior to Inception of the Period of Insurance) involving design, construction, Performance Testing and Commissioning in respect of the Works and shall Include capital expenditure, upgrade, modification, maintenance or overhaul, refurbishment, renovation, retrofitting or alterations and additions to existing facilities undertaken by the Insured or other Insured Parties acting on their behalf but **excluding**;

- a) contracts which at award stage have a value in excess of R 1,000,000,000;
- b) contracts with an estimated construction period exceeding 48 months but increasing to 60 months in respect of rail maintenance contracts and Transnet Freight and Rail contracts for logistical support for inline inspections and identification of defects over a 5 year period in respect of Transnet's pipeline assets (excluding Defects Liability/Maintenance period);
- c) contracts involving construction or erection of petrochemical manufacturing plant(s) but this exclusion shall not apply to pipelines and other associated works undertaken by or on behalf of the Insured;
- d) contracts in or on any aircraft;
- e) Off-shore contracts;
- f) Wet Risk Contracts which at award exceeds R500,000,000;
- g) Dam Contracts
- h) Tunnel contracts which at award exceeds R50,000,000;
- i) Tunnel contracts using tunnel boring machines;
- j) Underground Mining Contracts;
- k) Horizontal Directional Drilling Contracts which at award exceeds R50,000,000;
- l) Horizontal Directional Drilling Contracts where total drilling exceeds 1 km;
- m) Horizontal Directional Drilling Contracts for pipe diameters greater than 76 cm.

Definitions

1. "Off-shore contracts" means all works and installations in the sea or on the seabed including dredging which are accessible only by ship boat barge or helicopter and do not constitute normal wet works like harbours moles bridges wharves or sewage or cooling water intake or outlet facilities. "OffShore Contracts" shall include oilrigs and oil platforms (but not including oil platforms when connected to the land on completion). The term shall not apply to pre-fabrication works on land associated with an Off-Shore Contract.

- 2 *"Wet Risk Contracts" shall mean any Contract and/or Works where more than thirty-five (35) percentile of its value is in a permanent body of water or is below the high water mark of any tidal body of water. The term shall include contracts for the construction of wharves, piers, marinas, causeways, breakwaters, jetties, dry docks and offshore pipelines when connected directly to on-shore facilities and canal developments. Wet Risks shall exclude Off- Shore Contracts;*
- 3 *"Dam Contracts", which term shall include weirs and hydroelectric projects involving the construction of dams or weirs;*
- 4 *"Horizontal Directional Drilling Contracts", means micro-tunnelling work for the construction of tunnels utilising surface based horizontal directional drilling equipment.*
- 5 *Tunnels" means Tunnels (Including declines) involving all of the following;*
 - (a) Works below ground level; and
 - (b) Tunnelling machinery below ground level; and
 - (c) A tunnelling crew operating the machinery below ground level;
 - (d) But shall not include Horizontal Directional Drilling Contracts
- 6 *"Horizontal Directional Drilling Contracts", means micro-tunnelling work for the construction of tunnels utilising surface based horizontal directional drilling equipment.*
- 7 *"Underground Mining Contracts", which shall mean any contract involving underground mining.*

Testing Period: 120 Days not consecutive.

Maintenance Period : 12 Months

Main Policy Extensions :

- Costs & Expenses - Limited to maximum of R50,000,000.
- Expediting Measures – Limited to a maximum of R50,000,000.
- Professional Fees In Reinstatement Of Property Insured - Limited to a maximum of R50,000,000.
- Costs & Expenses For Removal Of Debris No Damage - Limited to a maximum of R50,000,000.
- Surrounding Property in care custody or control of the contractor – Limited to a maximum of R55,000,000.
- Fire Brigade & Public Authorities - Limited to a maximum of R10,000,000.
- Public Authority Reinstatement Costs - Limited to a maximum of R20,000,000
- Public Relationship Costs - Limited to a maximum of R1,000,000.
- Records - Limited to a maximum of R2,000,000.
- Removal to Gain Access - Limited to a maximum of R20,000,000

- Road Reserve and Servitude Extensions - Limited to a maximum of R10,000,000
- Search & Locate Costs - Limited to a maximum of R20,000,000.
- Borrowing Of Plant For Commissioning Purposes - Limited to a maximum of R10,000,000
- Escalation during Construction – 30%
- Marine Contribution Clause
- Claim Preparation Costs – Limited to a maximum of R10,000,000

Main Policy Exclusions :

- War
- Nuclear Energy Risks
- Terrorism
- Computer Loss General Exception
- DE4 (All types of Works) for defective material workmanship design plan or specification.
- LEG 3 (Mechanical or Electrical Engineering Works only) for defective material workmanship design plan or specification. Limited to maximum of 15% of the total estimated contract value.
- Loss or damage arising during air transit or any ocean voyage or whilst in storage thereafter.
- Occurring during any defects/maintenance period unless cause occurred prior to such defects/maintenance period
- Disappearance or by shortage revealed during routine inventory or periodic stocktaking.
- Consequential loss of whatsoever nature.
- Normal wear and tear, normal atmospheric conditions, rust, erosion, corrosion or oxidisation.
- Due to its own explosion breakdown or derangement occurring after the Testing Period which has operated under load conditions.
- Second hand property due to its own electrical or mechanical breakdown or explosion.

Deductibles:

In respect of loss or damage:

Major Perils shall mean damage caused by storm, rain, tempest, wind, flood, theft, malicious damage, subsidence, collapse, earthquake, testing or commissioning and the consequences of defective design, specification, materials or workmanship (DE4).

Minor Perils shall mean damage caused by a peril no defined as Major Perils defined above.

Contracts with a contract value :	Major perils	Minor perils
0 to R100,000,000	R25,000	R 15,000
R100,000,001 to R250,000,000	R50,000	R15,000
R250,000,001 to R500,000,000	R100,000	R25,000

R500,000,001 to R1,000,000,000 R150,000 R25,000

Minimum wet risk deductible of R100,000 per occurrence to apply.

LEG 3 Deductible (Only in respect of Mechanical and Electrical contracts);

Contracts with a contract value	Deductible
0 to R500,000,000	R1,000,000 per occurrence
R500,000,001 to R1,000,000,000	R1,500,000 per occurrence

PUBLIC LIABILITY

- Cover Provided : Contract Works Public Liability – cover the Insured’s legal liability in respect of loss or damage or injury to third parties arising out of work performed in respect of the Insured Contracts.
- Insurer : Stalker Hutchinson (Santam Limited)
- Policy Number: 6000/132335
- Territorial Limits : The Republic of South Africa.
- Insured Contracts: All contracts (including any undertaking awarded or commenced prior to inception of the period of Insurance) involving design, construction, performance testing and commissioning in respect of the works and shall include capital expenditure, upgrade, modification, maintenance or overhaul, refurbishment, renovation, retrofitting or alterations and additions to existing facilities undertaken by the Insured or other Insured Parties acting on their behalf but **Excluding**:
- a) Contracts which at award stage have a value in excess of R 1,000,000,000.
 - b) Contracts with an estimated construction period at award exceeding 48 months but 60 months in respect of contracts awarded prior to 1 April 2020 for rail maintenance contracts For Transnet Freight & Rail and for Transnet Pipeline’s logistical support for inline inspections and identification of defects in respect of Transnet’s pipeline assets (all excluding Defects Liability/Maintenance period).
 - c) Contracts with a Contractual Defects Liability Maintenance Period exceeding 24 months.
 - d) Contracts involving construction or erection of petrochemical manufacturing plant(s) but this exclusion shall not apply to pipelines and other associated works undertaken by or on behalf of the Insured.
 - e) Contracts in or on any aircraft.
 - f) Off-shore contracts - “Off-shore contracts” means all works and installations in the sea or on the seabed and do not constitute normal Wet Risk Contracts like harbours, moles, bridges, wharves or sewage or cooling water intake or outlet facilities, piers, marinas, causeways, breakwaters, jetties, dry docks and offshore pipelines when connected directly to onshore facilities and canal developments. "Off-Shore contracts" shall include oilrigs and oil platforms.

Policy Limits:

Contractors Public Liability	R100,000,000 any one occurrence / unlimited during the Period of Insurance
Contractors Negligent Removal or weakening of Support	R100 000 000 any one occurrence and R100,000,000 per site in the aggregate during the Period of Insurance.
Statutory Legal Defence Costs	*R5 000 000 in the aggregate during the Period of Insurance.
Arrest / Assault / Defamation	*R5 000 000 in the aggregate during the Period of Insurance.
Emergency Medical Expenses	R5 000 000 any one occurrence
Prevention of Access	*R5 000 000 in the aggregate during the Period of Insurance.
Trespass / Nuisance	*R5 000 000 in the aggregate during the Period of Insurance.
Claims Preparation Costs	R5 000 000 any one occurrence

*Where the limits are noted as in the aggregate during the policy period of insurance, that such aggregated limit is applicable to all Transnet Insured Contracts collectively and in total and does not apply to each contract separately.

Deductible(s) : R50,000 per occurrence but increased to R5,000,000 in respect of Spread of Fire and/or Hot Works and R250,000 in respect of Sudden and Accidental Pollution and/or Goods on the Hook.

General Policy Exclusions :

The policy does not cover:

- deliberate, conscious and intentional disregard to take reasonable precautions.
- fines, penalties, punitive and exemplary damages.
- Pollution unless caused by a sudden, unintended and unexpected occurrence.
- cost of removing, nullifying or cleaning up the effects of pollution unless caused by a sudden, unintended and unexpected occurrence.
- the hazardous nature of asbestos.
- War And Terrorism Risks.
- Nuclear Risks.
- Actual or alleged unlawful competition, unfair practices, abuse of monopoly power, cartel activities
- Compulsory Insurance
- Loss or damage and any consequence therefrom to any Data. •
- Sanctions Exclusion

PROFESSIONAL INDEMNITY

Cover Provided :	Professional Indemnity
	<ul style="list-style-type: none"> a) In respect of damages which the Insured shall become legally liable to pay in consequence of neglect, error or omission by or on behalf of the Insured in the conduct or execution of their Professional Activities and Duties as defined. b) Prior To Handover/Rectification - against loss arising out of any defect in the works discovered prior to the issue of any practical completion or take-over certificate provided that any such defects are caused by a negligent breach of a Professional Activity or Duty by the Insured in consequence of neglect, error or omission by or on behalf of the Insured.
Insurer :	Stalker Hutchinson (Santam Limited)
Policy Number:	6000/132337
Jurisdiction :	Worldwide excluding North America
Insured Contracts:	<p>All contracts (including any undertaking awarded or commenced prior to inception of the period of Insurance) involving design, construction, performance testing and commissioning in respect of the works and shall include capital expenditure, upgrade, modification, maintenance or overhaul, refurbishment, renovation, retrofitting or alterations and additions to existing facilities undertaken by the Insured or other Insured Parties acting on their behalf but Excluding:</p> <ul style="list-style-type: none"> a) Contracts which at award stage have a value in excess of R 1,000,000,000. b) Contracts with an estimated construction period at award exceeding 48 months (excluding Defects Liability/Maintenance period). c) Contracts with a Contractual Defects Liability Maintenance Period exceeding 24 months. d) Contracts involving construction or erection of petrochemical manufacturing plant(s) but this exclusion shall not apply to pipelines and other associated works undertaken by or on behalf of the Insured. e) Contracts in or on any aircraft. f) Off-shore contracts - "Off-shore contracts" means all works and installations in the sea or on the seabed and do not constitute normal Wet Risk Contracts like harbours, moles, bridges, wharves or sewage or cooling water intake or outlet facilities, piers, marinas, causeways, breakwaters, jetties, dry docks and offshore pipelines when connected directly to onshore facilities and canal developments. "Off-Shore contracts" shall include oilrigs and oil platforms.
Limit Of Indemnity:	Professional Indemnity - *R100,000,000 in the aggregate during the policy period of insurance.

*Where the limit is noted as in the aggregate during the policy period of insurance, that such aggregated limit is applicable to all Transnet Insured Contracts collectively and in total and does not apply to each contract separately.

Policy Extension
Limits Of Indemnity:

Claims Preparation Costs -	*R7,500,000 in the aggregate during the policy period of insurance.
Loss of Documents -	*R2,000,000 in the aggregate during the policy period of insurance.
Statutory Defence Costs -	*R5,000,000 in the aggregate during the policy period of insurance.
Defamation -	*R5,000,000 in the aggregate during the policy period of insurance. R 10,000 R 5,000,000 R 5,000,000
Infringement of Copyright -	*R5,000,000 in the aggregate during the policy period of insurance.

*Where the limits are noted as in the aggregate during the policy period of insurance, that such aggregated limit is applicable to all Transnet Insured Contracts collectively and in total and does not apply to each contract separately.

Deductibles:

R5,000,000 each and every but R10,000 in respect of Claims Preparation Costs, Loss of Documents, Statutory Defence Costs, Defamation and Infringement Of Copyright.

Policy Special Conditions :

Condition precedent to liability that the Insured is fully qualified and registered with the relevant Industry Body/Association in terms of legislation as applicable.

Prior to hand over/rectification – the insured must give prior written notice to the Insurers of the intention to take remedial action to rectify such defect and obtain the Insurers' written agreement to such action being taken and the costs and expenses expected to be expended.

Policy Main Exclusions:

- Excludes all consequential loss other than cost of re-design, rectification and replacement as a consequence of the defect.
- Excludes Supervision.
- Excludes liability arising out of environmental impairment / pollution
- Excludes the cost of removing, nullifying or cleaning-up the effects of environmental impairment/ pollution.
- Excludes war, invasion, acts of foreign enemies, hostilities or warlike operations (whether war be declared or not), civil war, rebellion, revolution, insurrection, civil commotion assuming the proportions of or amounting to an uprising, military or usurped power, any act of terrorism and nuclear risks.
- Excludes fines, penalties, punitive and exemplary damages, multiplication of compensatory damages and/or any other noncompensating damages of any kind.
- Excludes liability from the hazardous nature of asbestos.
- Excludes medical malpractice.

- Excludes failure to meet contractual requirements relating to efficiency, output or durability.
- Excludes failure to meet completion dates
- Excludes the estimation of probable costs other than cost advice and cost planning services normally provided by a Quantity Surveyor or Project manager.
- Excludes incorrect authorisation of payment.
- Excludes breach of any statutory regulation.
- Excludes liability from the insolvency, liquidation or judicial management of the Insured.
- Excludes the certification of value of work executed by any contractor where the Insured has an equity interest in such contractor;
- Excludes liability due to unlawful competition, unfair practices, abuse of monopoly power, cartel activities or breach of a competitions ac
- Sanctions Exclusion

This certificate of the insurance cover arranged is issued as a matter of information only and confers no rights upon the certificate holder. This certificate does not amend, extend or alter the coverage afforded by the policies issued by Insurers.

Dennis Govender



Chief Broking Officer